

# STRUT CHANNELS SYSTEMS

- **STRAIGHT SECTIONS**
- **CONCRETE INSERTS**
- **FITTINGS**
- **CHANNEL NUTS & HARDWARE**
- **MECHANICAL ACCESSORIES**
- **ENGINEERING DATA**



### M1000 CHANNEL

Wt: 2.65kg/mtr (Steel)

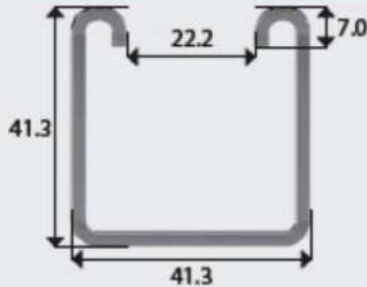

#### Product Details

Metalone M1000 Channel section is manufactured from strip steel to the following standards:

- **Mild steel & Hot Dip Galvanised** to ASTM A 36 & after fabrication **As per:** ASTM A 123 / ASTM A 153 / ISO 1461. BS 729 / DIN 50976
- **Pre-Galvanised to As per:** EN 10327 / DIN 17162 / BS 2989 / ASTM A 527M / ASTM A 653M/ JIS G 3302. EN 10326 / EN 10142 / ASTM A 526, 527, 528 / ASTM A 146
- **Stainless Steel** - Austenitic Stainless Steels ASI 304 & 316, As per: BS 1449

#### Material Specification

Thickness 1.5mm, 2.0mm, 2.5mm  
Length 3m & 6m

#### Ordering Details

Supplied in standard 3m lengths

**Available Finish**                      **Ordering Code**

Mill (Plain)                                M1000P  
Pre-Galvanised                            M1000G  
Hot Dip Galvanised                      M1000H  
Stainless Steel                             M1000S

Fibre Reinforced                         M1000FRP  
Plastic (FRP) (see special edition catalog for details)

#### TECHNICAL DETAILS

The load values shown are in accordance with ASTM A 653 using a minimum yield stress for Fy of 210 MPa on plain channels.

The published results are based on a uniformly loaded, simply supported span.

Deflection has been calculated using standard formulae at the maximum permissible stress.

Span (mm)	Max. Allowable Load (kg)	Deflection at Allowable Load (mm)
250	1308	0.17
500	654	0.68
750	436	1.53
1000	328	2.72
1250	261	4.25
1500	218	6.13
1750	187	8.34
2000	163	10.90
2250	145	13.80
2500	131	17.03
2750	119	20.61
3000	109	24.56

### M2000 RIBBED CHANNEL

Wt: 1.78kg/mtr (Steel)  
Wt: 0.61kg/mtr (Aluminium)

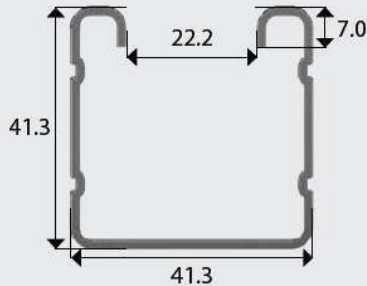

#### Product Details

Metalone M1000 Channel section is manufactured from strip steel to the following standards:

- **Mild steel & Hot Dip Galvanised** to ASTM A 36 & after fabrication  
**As per:** ASTM A 123 / ASTM A 153 / ISO 1461. BS 729 / DIN 50976
- **Pre-Galvanised to As per:** EN 10327 / DIN 17162 / BS 2989 / ASTM A 527M / ASTM A 653M/ JIS G 3302. EN 10326 / EN 10142 / ASTM A 526, 527, 528 / ASTM A 146
- **Stainless Steel** - Austenitic Stainless Steels ASI 304 & 316, As per: BS 1449

#### Material Specification

Thickness 1.5mm, 2.0mm, 2.5mm  
Length 3m & 6m

#### Ordering Details

Supplied in standard 3m lengths

Available Finish	Ordering Code
Mill (Plain)	M2000P
Pre-Galvanised	M2000G
Hot Dip Galvanised	M2000H
Aluminium	M2000A

#### TECHNICAL DETAILS

The load values shown are in accordance with ASTM A 653 using a minimum yield stress for Fy of 210 MPa on plain channels.

The published results are based on a uniformly loaded, simply supported span.

Deflection has been calculated using standard formulae at the maximum permissible stress.

Span (mm)	Max. Allowable Load (kg)	Deflection at Allowable Load (mm)
250	945	0.16
500	471	0.65
750	314	1.46
1000	236	2.59
1250	189	4.05
1500	157	5.84
1750	135	7.94
2000	117	10.37
2250	105	13.80
2500	94	16.20
2750	85	19.62
3000	78	23.34

### M3300 CHANNEL

Wt: 1.88kg/mtr (Steel)

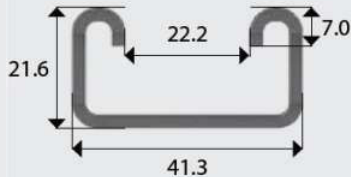

#### Product Details

Metalone M1000 Channel section is manufactured from strip steel to the following standards:

- **Mild steel & Hot Dip Galvanised** to ASTM A 36 & after fabrication  
As per: ASTM A 123 / ASTM A 153 / ISO 1461. BS 729 / DIN 50976
- **Pre-Galvanised** to As per: EN 10327 / DIN 17162 / BS 2989 / ASTM A 527M / ASTM A 653M/ JIS G 3302. EN 10326 / EN 10142 / ASTM A 526, 527, 528 / ASTM A 146
- **Stainless Steel** - Austenitic Stainless Steels ASI 304 & 316, As per: BS 1449

#### Material Specification

Thickness 1.5mm, 2.0mm, 2.5mm  
Length 3m & 6m

#### Ordering Details

Supplied in standard 3m lengths

Available Finish	Ordering Code
Mill (Plain)	M3300P
Pre-Galvanised	M3300G
Hot Dip Galvanised	M3300H
Stainless Steel	M3300S

#### TECHNICAL DETAILS

The load values shown are in accordance with ASTM A 653 using a minimum yield stress for Fy of 210 MPa on plain channels.

The published results are based on a uniformly loaded, simply supported span.

Deflection has been calculated using standard formulae at the maximum permissible stress.

Span (mm)	Max. Allowable Load (kg)	Deflection at Allowable Load (mm)
250	442	0.29
500	221	1.17
750	147	2.64
1000	110	4.69
1250	89	7.34
1500	73	10.57
1750	63	14.39
2000	55	18.79
2250	49	23.78
2500	44	29.35
2750	40	35.52
3000	37	42.27

### M4000 RIBBED CHANNEL

Wt: 1.27kg/mtr (Steel)  
Wt: 0.43kg/mtr (Aluminium)

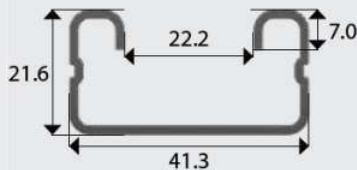

#### Product Details

Metalone M1000 Channel section is manufactured from strip steel to the following standards:

- **Mild steel & Hot Dip Galvanised** to ASTM A 36 & after fabrication  
**As per:** ASTM A 123 / ASTM A 153 / ISO 1461. BS 729 / DIN 50976
- **Pre-Galvanised** to **As per:** EN 10327 / DIN 17162 / BS 2989 / ASTM A 527M / ASTM A 653M/ JIS G 3302. EN 10326 / EN 10142 / ASTM A 526, 527, 528 / ASTM A 146
- **Stainless Steel** - Austenitic Stainless Steels ASI 304 & 316, As per: BS 1449

#### Material Specification

Thickness 1.5mm, 2.0mm, 2.5mm  
Length 3m & 6m

#### Ordering Details

Supplied in standard 3m lengths

Available Finish	Ordering Code
Mill (Plain)	M4000P
Pre-Galvanised	M4000G
Hot Dip Galvanised	M4000H
Aluminium	M4000A

#### TECHNICAL DETAILS

The load values shown are in accordance with ASTM A 653 using a minimum yield stress for Fy of 210 MPa on plain channels.

The published results are based on a uniformly loaded, simply supported span.

Deflection has been calculated using standard formulae at the maximum permissible stress.

Span (mm)	Max. Allowable Load (kg)	Deflection at Allowable Load (mm)
250	350	0.31
500	175	1.22
750	116	2.76
1000	88	4.89
1250	70	7.65
1500	58	11.02
1750	50	15.00
2000	44	19.59
2250	39	24.82
2500	35	30.61
2750	32	37.04
3000	30	44.15

### M5500 CHANNEL

Wt: 3.43kg/mtr (Steel)

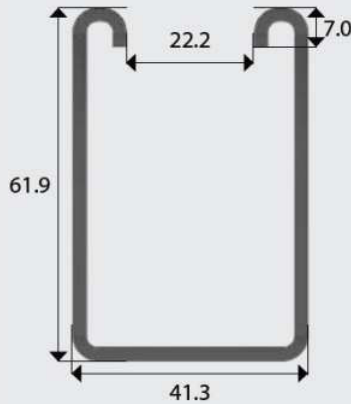

#### Product Details

Metalone M1000 Channel section is manufactured from strip steel to the following standards:

- **Mild steel & Hot Dip Galvanised** to ASTM A 36 & after fabrication **As per:** ASTM A 123 / ASTM A 153 / ISO 1461. BS 729 / DIN 50976
- **Pre-Galvanised to As per:** EN 10327 / DIN 17162 / BS 2989 / ASTM A 527M / ASTM A 653M/ JIS G 3302. EN 10326 / EN 10142 / ASTM A 526, 527, 528 / ASTM A 146
- **Stainless Steel** - Austenitic Stainless Steels ASI 304 & 316, As per: BS 1449

#### Material Specification

Thickness 1.5mm, 2.0mm, 2.5mm  
Length 3m & 6m

#### Ordering Details

Supplied in standard 6m lengths

Available Finish	Ordering Code
Mill (Plain)	M5500P
Pre-Galvanised	M5500G
Hot Dip Galvanised	M5500H

#### TECHNICAL DETAILS

The load values shown are in accordance with ASTM A 653 using a minimum yield stress for Fy of 210 MPa on plain channels.

The published results are based on a uniformly loaded, simply supported span.

Deflection has been calculated using standard formulae at the maximum permissible stress.

Span (mm)	Max. Allowable Load (kg)	Deflection at Allowable Load (mm)
250	2488	0.11
500	1244	0.45
750	830	1.02
1000	622	1.81
1250	498	2.82
1500	414	4.06
1750	355	5.54
2000	311	7.23
2250	276	9.16
2500	249	11.30
2750	226	13.68
3000	207	16.28

# STRUT CHANNEL SYSTEMS

## Straight Sections

### Product Details

Metalone Slotted Channel sections are manufactured from strip steel to the following standards:

- **Mild steel & Hot Dip Galvanised** to ASTM A 36 & after fabrication **As per:** ASTM A 123 / ASTM A 153 / ISO 1461. BS 729 / DIN 50976
- **Pre-Galvanised** to **As per:** EN 10327 / DIN 17162 / BS 2989 / ASTM A 527M / ASTM A 653M/ JIS G 3302. EN 10326 / EN 10142 / ASTM A 526, 527, 528 / ASTM A 146
- **Stainless Steel** - Austenitic Stainless Steels ASI 304 & 316, As per: BS 1449
- or from extruded aluminium alloy 6063-T5

### SLOTTING DETAILS

30 x 14mm slots are punched continuously at 50mm centres

### Material Specification

Thickness 1.5, 2, 2.5mm  
Length 3/6m

### Ordering Details

Supplied in standard 3m lengths

Available Finish	Ordering Code
Pre-Galvanised	M...SG
Hot Dip Galvanised	M...SH
Stainless Steel (M1000 and M3300 profiles only)	M...SS
Aluminium (M2000 and M4000 profiles only)	M...SA

Example: To order M1000 Slotted in Hot Dip Galvanised, use product code: M1000SH

### M1000S

Wt: 2.32kg/mtr (Steel)

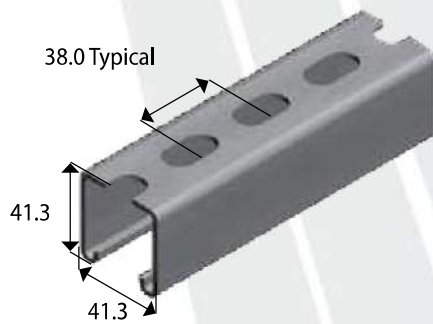

### M4000S

Wt: 1.09kg/mtr (Steel)  
Wt: 0.21kg/mtr (Aluminium)

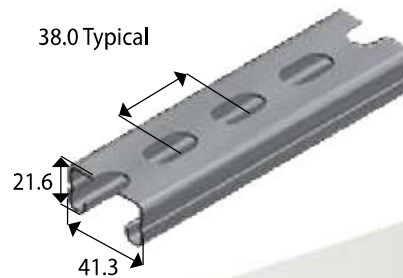

### M2000S

Wt: 1.60kg/mtr (Steel)  
Wt: 0.39kg/mtr (Aluminium)

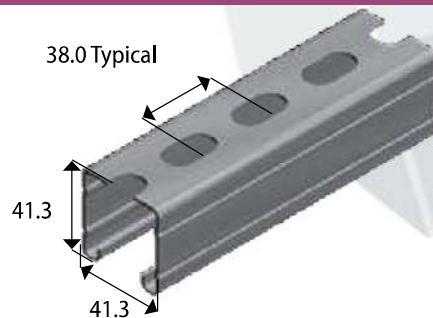

### M5500S

Wt: 3.10kg/mtr (Steel)

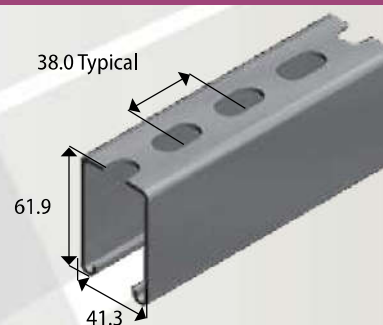

### M3300S

Wt: 1.54kg/mtr (Steel)

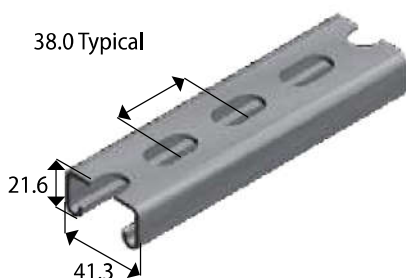

# STRUT CHANNEL SYSTEMS

## Straight Sections

### Product Details

Metalone Combination Channel sections are manufactured from strip steel to the following standards:

- **Mild steel & Hot Dip Galvanised** to ASTM A 36 & after fabrication **As per:** ASTM A 123 / ASTM A 153 / ISO 1461. BS 729 / DIN 50976
- **Pre-Galvanised** to **As per:** EN 10327 / DIN 17162 / BS 2989 / ASTM A 527M / ASTM A 653M/ JIS G 3302. EN 10326 / EN 10142 / ASTM A 526, 527, 528 / ASTM A 146
- **Stainless Steel** - Austenitic Stainless Steels ASI 304 & 316, As per: BS 1449
- or from extruded aluminium alloy 6063-T5

### Welding Details

The channel is continuously spot welded at a maximum of 150 centres

### Material Specification

Length 3/6m

### Ordering Details

Supplied in standard 3m lengths

Available Finish	Ordering Code
Pre-Galvanised	M...1G
Hot Dip Galvanised	M...1H
Stainless Steel (M1000 and M3300 profiles only)	M...1S
Aluminium (M2000 and M4000 profiles only)	M...1A

All Combination Channel other than M1001H is manufactured against firm orders only.

**M1001**

Wt: 5.30kg/mtr (Steel)

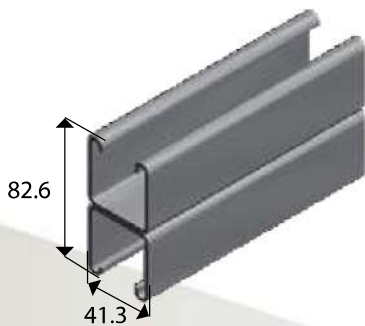

**M4001**

Wt: 2.54kg/mtr (Steel)  
Wt: 0.86kg/mtr (Aluminium)

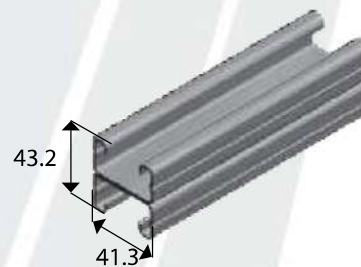

**M2001**

Wt: 3.56kg/mtr (Steel)  
Wt: 1.22kg/mtr (Aluminium)

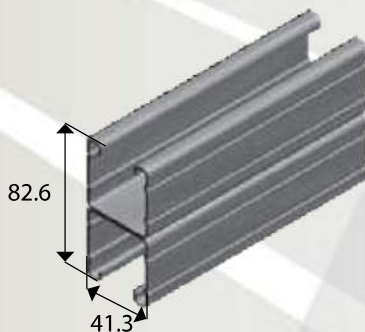

**M5501**

Wt: 6.86kg/mtr (Steel)

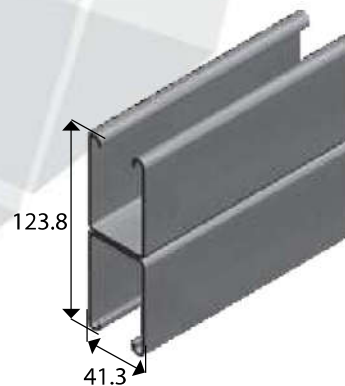

**M3301**

Wt: 3.76kg/mtr (Steel)

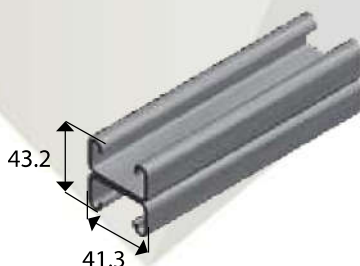

# STRUT CHANNEL SYSTEMS

## Straight Sections

### Product Details

Metalone Combination Channel sections are manufactured from strip steel to the following standards:

- **Mild steel & Hot Dip Galvanised** to ASTM A 36 & after fabrication **As per:** ASTM A 123 / ASTM A 153 / ISO 1461. BS 729 / DIN 50976
- **Pre-Galvanised** to **As per:** EN 10327 / DIN 17162 / BS 2989 / ASTM A 527M / ASTM A 653M/ JIS G 3302. EN 10326 / EN 10142 / ASTM A 526, 527, 528 / ASTM A 146
- **Stainless Steel** - Austenitic Stainless Steels ASI 304 & 316, As per: BS 1449
- or from extruded aluminium alloy 6063-T5

### Welding Details

The channel is continuously spot welded at a maximum of 150 centres

### Material Specification

Length 3/6m

### Ordering Details

Supplied in standard 3m lengths

Available Finish	Ordering Code
------------------	---------------

Hot Dip Galvanised	M...1...H
--------------------	-----------

Stainless Steel (M1000 and M3300 profiles only)	M...1...S
--	-----------

Most channel combinations can also be manufactured from other strut profiles. To order simply change the digits to represent the strut profile.

Example: To use M2000 channel, the product code would be M2001-xx

All Combination Channel other than M1001H is manufactured against firm orders only.

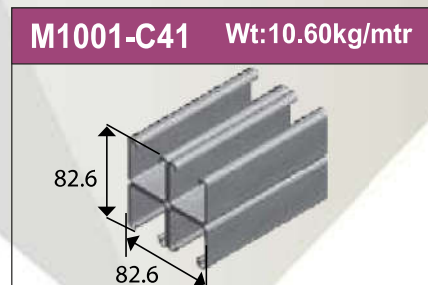
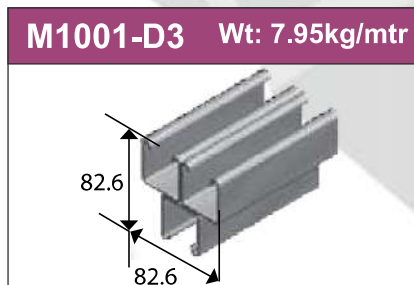
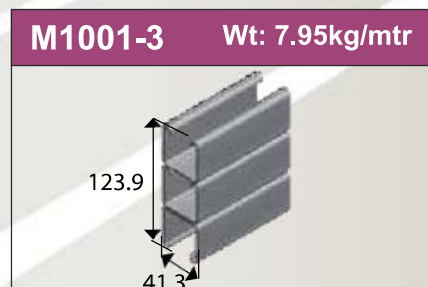
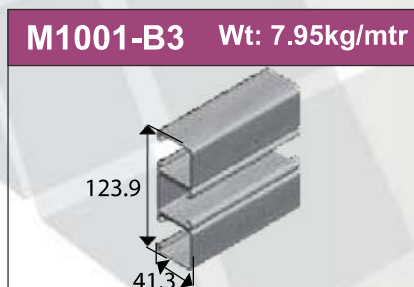
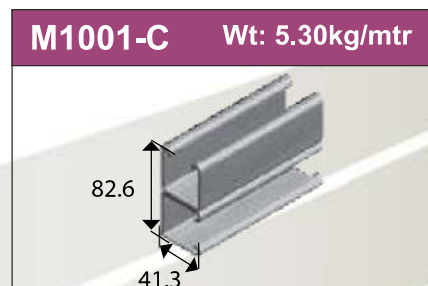
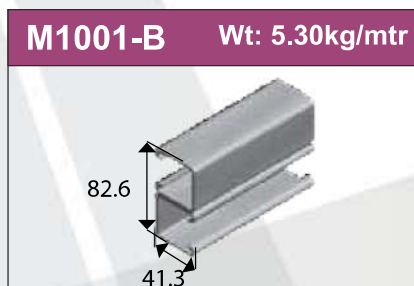
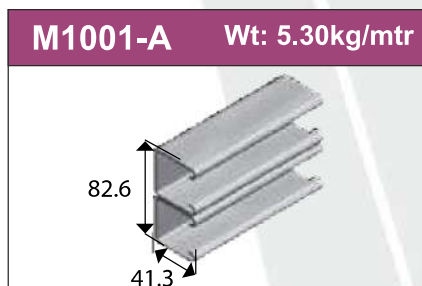

### Product Details

Metalone Concrete Insert Channel is manufactured from strip steel to the following standards:

- **Mild steel & Hot Dip Galvanised** to ASTM A 36 & after fabrication **As per:** ASTM A 123 / ASTM A 153 / ISO 1461. BS 729 / DIN 50976
- Lugs are punched continuously along the channel length at
- 200mm centres.

### Loading details

M1000CI Testing on 200mm section confirms a maximum pullout load of 1030kg with a safety factor of 3.

M3300CI Testing on 200mm section confirms a maximum pullout load of 600kg with a safety factor of 3.

### NOTES

- The tests were carried out in controlled laboratory conditions using a concrete strength of 25MPa (average).
- The rated load performance will change when using other concrete strengths and depending on positioning of the concrete reinforcing mesh.

### Ordering Details

#### Supplied in standard 3m lengths

Channel can be supplied pre cut in increments of 200mm (nominal).

Cutting charges and minimum order quantities may apply.

#### Available

#### Finish

Hot Dip Galvanised

#### Ordering

#### Code

M...CIH

### M1000CI

Wt: 2.86kg/mtr

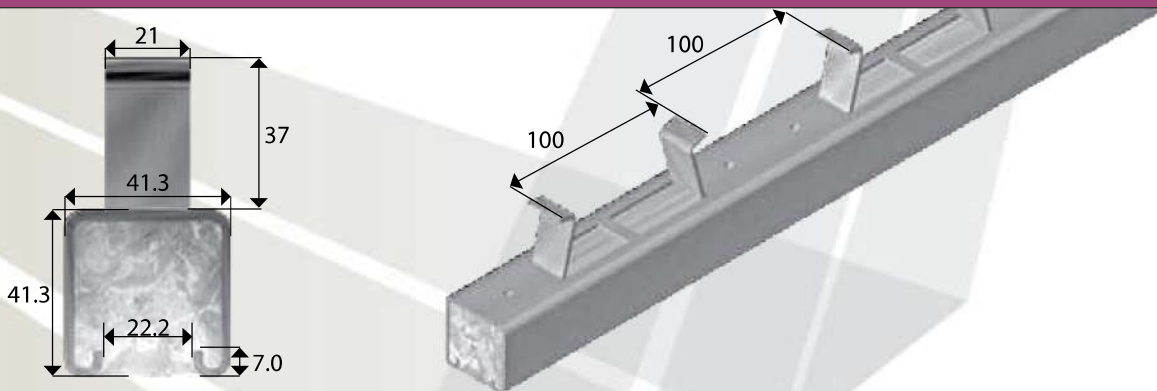

### M3300CI

Wt: 2.00kg/mtr

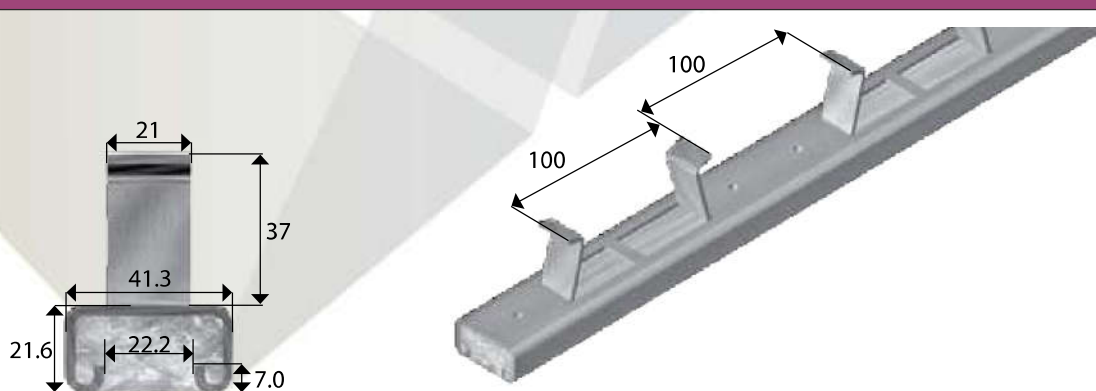

## Fittings

### Product Detail

Metalone provides a range of plastic accessories to complement most channel sections.

Commonly used in lighting grid applications, channels are easy transformed into cable conduits using the channel cover strip and range of end caps.

### Ordering Details

Supplied individually

#### Available Finish

White/Grey Plastic  
Aluminium

#### Ordering Code

M...P  
M...A  
(M1184 Only)

### M1184



### M1180



### M3380



### M5580

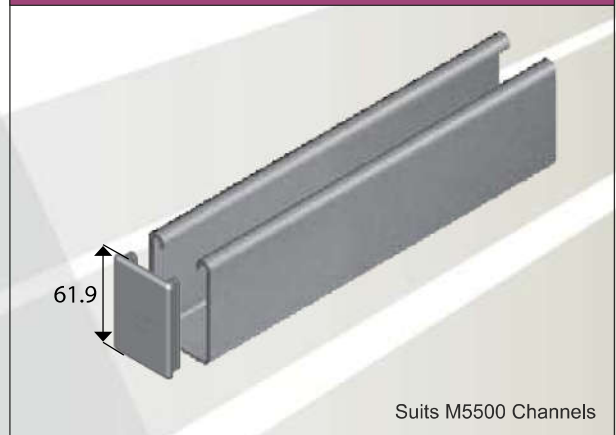

### M2552

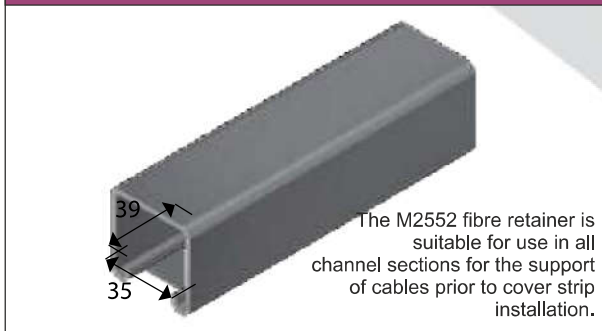

NO-TWIST SQUARE WASHERS						
CATALOG NUMBER	BOLT SIZE		HOLE SIZE		WEIGHT PER 100	
	in	mm	in	mm	lbs	kg
MOSC-1002	5/16	7.9	11/32	8.7	17	7.7
MOSC-1003	3/8	9.5	7/16	11.1	16	7.3
MOSC-1004	17/2	12.7	9/16	14.3	15	6.8
MOSC-1005	5/8	15.9	11/16	17.5	15	6.8
MOSC-1006	3/4	19.0	13/16	20.6	4	6.3

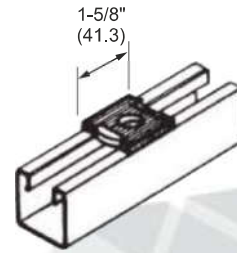

TWO-HOLE SPLICE PLATE	
CATALOG NUMBER	WEIGHT PER 100
MOSC-1007	38 Lbs (17.2 Kg)

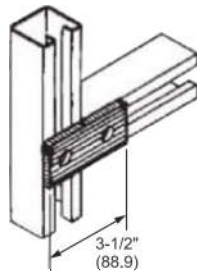

THREE-HOLE SPLICE PLATE	
CATALOG NUMBER	WEIGHT PER 100
MOSC-1012	74 Lbs (33.6 Kg)

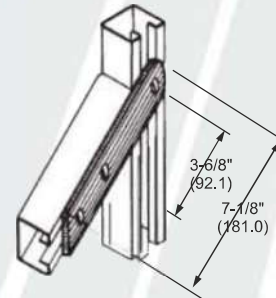

THREE-HOLE SPLICE PLATE	
CATALOG NUMBER	WEIGHT PER 100
MOSC-1008	59 Lbs (26.8 Kg)

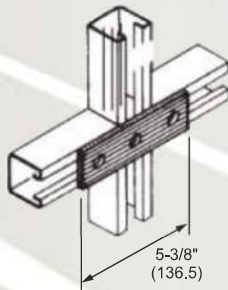

FLAT ANGLE PLATE	
CATALOG NUMBER	WEIGHT PER 100
MOSC-1021	58 Lbs (26.3 Kg)

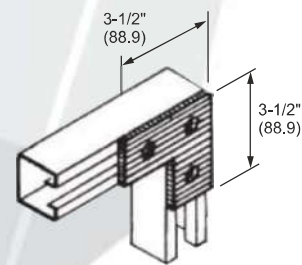

FOUR-HOLE SPLICE PLATE	
CATALOG NUMBER	WEIGHT PER 100
MOSC-1009	76 Lbs (34.5 Kg)

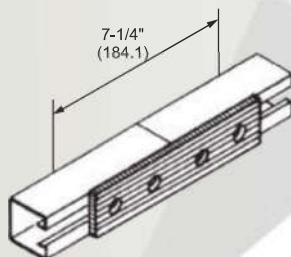

TEE PLATE	
CATALOG NUMBER	WEIGHT PER 100
MOSC-1022	80 Lbs (36.3 Kg)

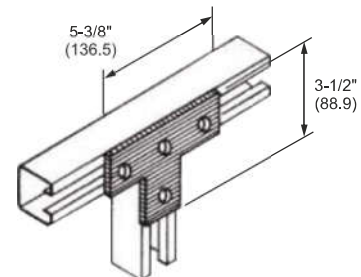

**Typical Dimensions:** Unless Otherwise shown all fittings will be as follows: Width 1-5/8" (41.3) : thickness 1/4" (6.3) : hole diameter 9/16" (14.3) : hole spacing 1-7/8" (47.6) on center and 13/16" (20.6) from end.  
Standard Finish: Electro-galvanized steel.

CROSS PLATE	
CATALOG NUMBER	WEIGHT PER 100
MOSC-1023	100 Lbs (45.4 Kg)

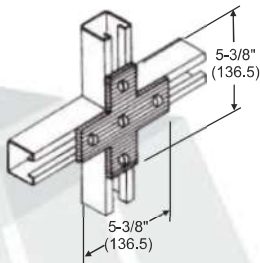

TWO-HOLE RACK CONNECTOR ANGLE	
CATALOG NUMBER	WEIGHT PER 100
MOSC-1102	36 Lbs (16.3 Kg)

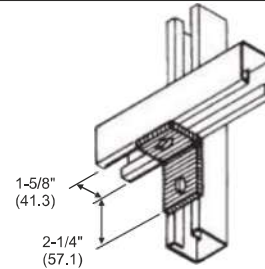

FOUR-HOLE GUSSET PLATE	
CATALOG NUMBER	WEIGHT PER 100
MOSC-1024	105 Lbs (47.6 Kg)

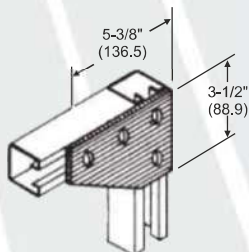

TWO-HOLE END CONNECTOR ANGLE	
CATALOG NUMBER	WEIGHT PER 100
MOSC-1103	36 Lbs (16.3 Kg)

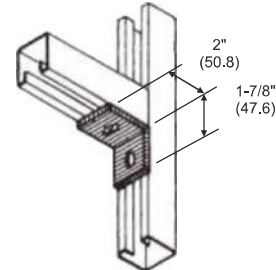

FOUR-HOLE GUSSET PLATE	
CATALOG NUMBER	WEIGHT PER 100
MOSC-1026	100 Lbs (45.84 Kg)

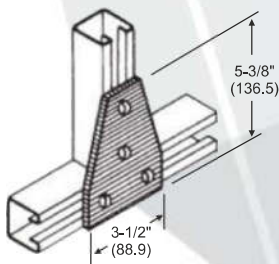

TWO-HOLE "NO-TWIST" CORNER ANGLE	
CATALOG NUMBER	WEIGHT PER 100
MOSC-1104	40 Lbs (18.1 Kg)

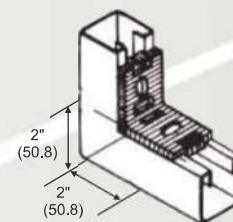

FIVE-HOLE GUSSET PLATE	
CATALOG NUMBER	WEIGHT PER 100
MOSC-1027	145 Lbs (65.8 Kg)

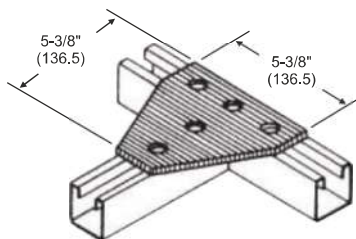

TWO-HOLE ADJUSTMENT ANGLE 2"	
CATALOG NUMBER	WEIGHT PER 100
MOSC-1105	40 Lbs (18.1 Kg)

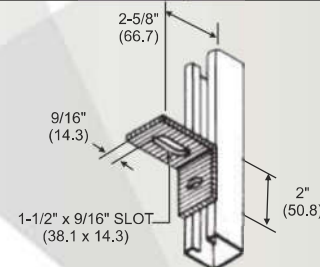

**Typical Dimensions:** Unless Otherwise shown all fittings will be as follows: Width 1-5/8" (41.3) : thickness 1/4" (6.3) : hole diameter 9/16" (14.3) : hole spacing 1-7/8" (47.6) on center and 13/16" (20.6) from end.  
Standard Finish: Electro-galvanized steel.

TWO-HOLE ADJUSTMENT ANGLE	
CATALOG NUMBER	WEIGHT PER 100
MOSC-1106	36 Lbs (16.3 Kg)

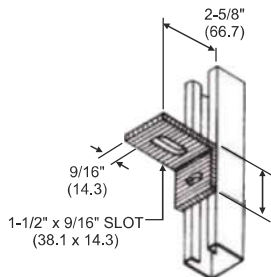

THREE-HOLE SELF ANGLE	
CATALOG NUMBER	WEIGHT PER 100
MOSC-1110	67 Lbs (30.4 Kg)

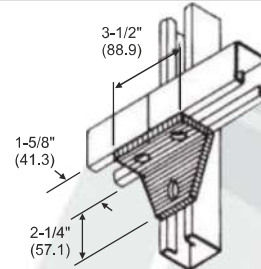

TWO-HOLE ADJUSTMENT ANGLE	
CATALOG NUMBER	WEIGHT PER 100
MOSC-1107	65 Lbs (29.5 Kg)

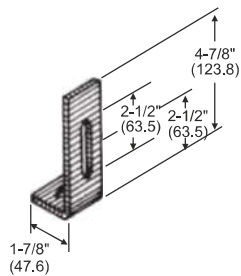

THREE-HOLE RACK CONNECTOR ANGLE	
CATALOG NUMBER	WEIGHT PER 100
MOSC-1112	58 Lbs (26.3 Kg)

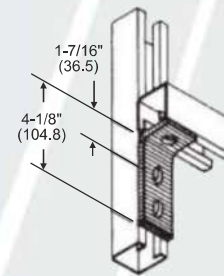

TWO-HOLE ADJUSTMENT ANGLE	
CATALOG NUMBER	WEIGHT PER 100
MOSC-1108	85 Lbs (38.6 Kg)

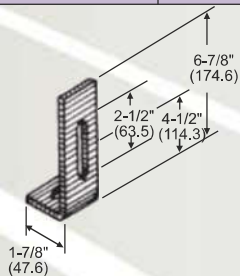

THREE-HOLE END CONNECTOR ANGLE	
CATALOG NUMBER	WEIGHT PER 100
MOSC-1113	58 Lbs (26.3 Kg)

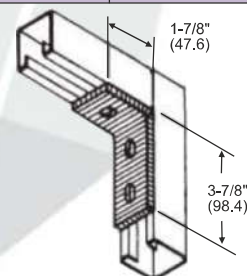

FOUR-HOLE SHELF ANGLE	
CATALOG NUMBER	WEIGHT PER 100
MOSC-1109	102 Lbs (46.3 Kg)

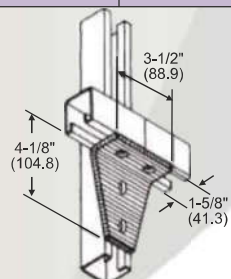

THREE-HOLE RACK CORNER ANGLE	
CATALOG NUMBER	WEIGHT PER 100
MOSC-1115	54 Lbs (24.5 Kg)

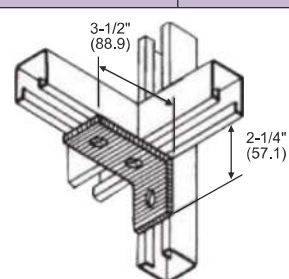

**Typical Dimensions:** Unless Otherwise shown all fittings will be as follows: Width 1-5/8" (41.3) : thickness 1/4" (6.3) : hole diameter 9/16" (14.3) : hole spacing 1-7/8" (47.6) on center and 13/16" (20.6) from end.  
**Standard Finish:** Electro-galvanized steel.

FIVE-HOLE THREE-WAY SELF ANGLE	
CATALOG NUMBER	WEIGHT PER 100
MOSC-1117	135 Lbs (61.2 Kg)

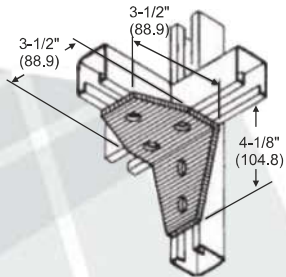

THREE-HOLE CORNER ANGLE	
CATALOG NUMBER	WEIGHT PER 100
MOSC-1125	76 Lbs (34.5 Kg)

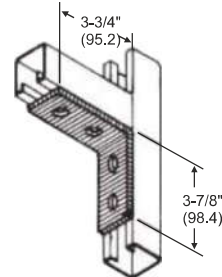

FIVE-HOLE RACK CORNER ANGLE	
CATALOG NUMBER	WEIGHT PER 100
MOSC-1123	74 Lbs (33.6 Kg)

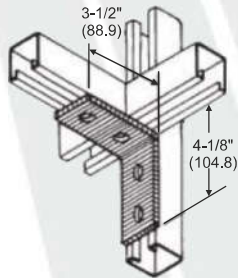

THREE-HOLE BENT ANGLE RIGHT HAND	
CATALOG NUMBER	WEIGHT PER 100
MOSC-1135	65 Lbs (29.5 Kg)

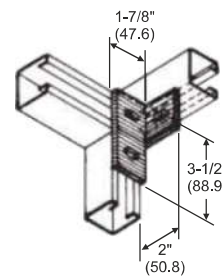

UNIVERSAL SELF BRACKET	
CATALOG NUMBER	WEIGHT PER 100
MOSC-1124	132 Lbs (59.9 Kg)

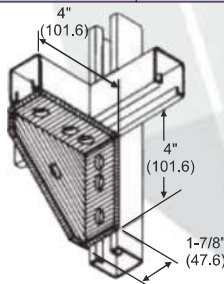

THREE-HOLE BENT ANGLE LEFT HAND	
CATALOG NUMBER	WEIGHT PER 100
MOSC-1136	65 Lbs (29.5 Kg)

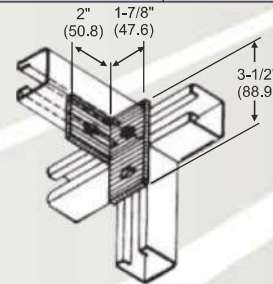

"Z" SUPPORTS					
CATALOG NUMBER	CHANNEL	A		WEIGHT PER 100	
		in	mm	lbs	kg
MOSC-1209	MO-100A	4-7/8	123.8	93	42.1
MOSC-1210	MO-150 MO-200A	3-1/4	82.6	70	31.8
MOSC-1211	MO-100	2-7/16	61.9	67	30.4
MOSC-1212	MO-200	1-5/8	41.3	55	24.9
MOSC-1213	MO-300	1-3/8	34.9	53	24.0
MOSC-1215	MO-400 MO-500A	13/16	20.6	47	21.3
	MO-800	1	25.4	47	21.3

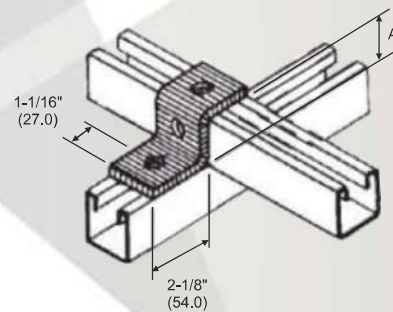

**Typical Dimensions:** Unless Otherwise shown all fittings will be as follows: Width 1-5/8" (41.3) : thickness 1/4" (6.3) : hole diameter 9/16" (14.3) : hole spacing 1-7/8" (47.6) on center and 13/16" (20.6) from end.  
Standard Finish: Electro-galvanized steel.

TWO-HOLE "Z" SUPPORTS				
CATALOG NUMBER	A		WEIGHT PER 100	
	in	mm	lbs	kg
MOSC-1224	4	101.6	77	34.9
MOSC-1225	5	127.0	95	43.1
MOSC-1226	6	152.4	98	44.4
MOSC-1227	7	177.8	105	47.6
MOSC-1228	8	203.2	120	54.4

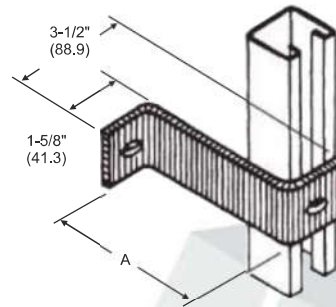

"U" SUPPORTS					
CATALOG NUMBER	CHANNEL	A		WEIGHT PER 100	
		in	mm	lbs	kg
MOSC-1311	MO-100	2-7/8	31.9	110	49.9
MOSC-1313	MO-300	1-3/8	34.9	84	38.1
MOSC-1315	MO-400 MO-500A	3-1/4	82.6	128	58.0
MOSC-1316	MO-150 MO-200A	3-1/4	82.6	128	58.0
MOSC-1318	MO-800	1	25.4	76	34.5

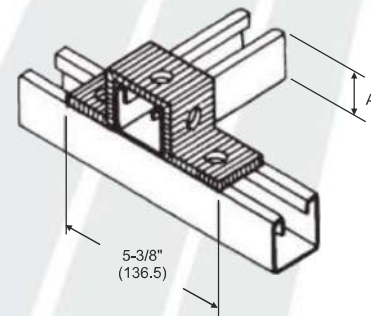

"U" SUPPORT FOR MOC-200 CHANNEL		
CATALOG NUMBER	WEIGHT PER 100	
MOSC-1312	85 Lbs	(38.6 Kg)

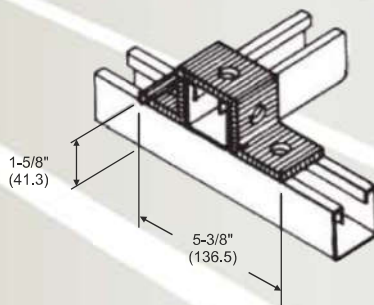

SIX-HOLE "U" SUPPORT	
CATALOG NUMBER	WEIGHT PER 100
MOSC-1317	105 Lbs (47.6 Kg)

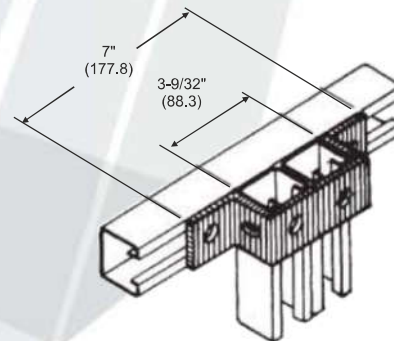

TWO-HOLE CLEVIS				
CATALOG NUMBER	A		WEIGHT PER 100	
	in	mm	lbs	kg
MOSC-1324	4	101.6	80	36.3
MOSC-1325	5	127.0	89	40.4
MOSC-1326	6	152.4	101	45.8
MOSC-1327	7	177.8	112	50.8
MOSC-1328	8	203.2	124	56.2

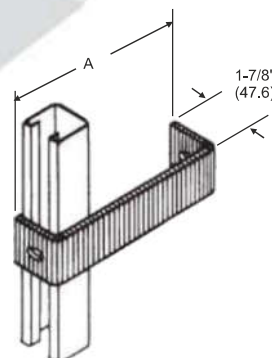

**Typical Dimensions:** Unless Otherwise shown all fittings will be as follows: Width 1-5/8" (41.3) : thickness 1/4" (6.3) : hole diameter 9/16" (14.3) : hole spacing 1-7/8" (47.6) on center and 13/16" (20.6) from end.  
Standard Finish: Electro-galvanized steel.

## Fittings

### 2-HOLE SPLICE CLEVIS FOR PW-500

CATALOG NUMBER	WEIGHT PER 100
MOSC-1342	84 Lbs (38.1 Kg)

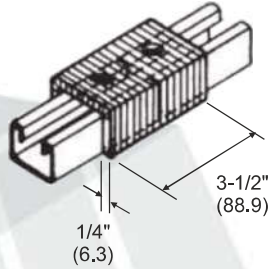

### 2-HOLE SPLICE CLEVIS FOR PW-200,210

CATALOG NUMBER	WEIGHT PER 100
PW-1344	123 Lbs (55.8 Kg)

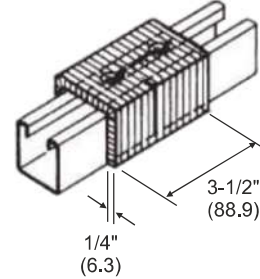

### 3-HOLE SPLICE CLEVIS FOR PW-500

CATALOG NUMBER	WEIGHT PER 100
PW-1343	126 Lbs (57.1 Kg)

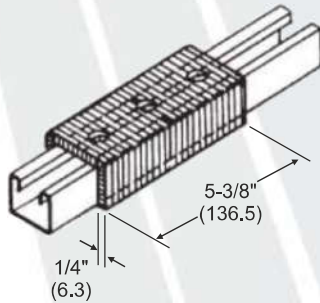

### 4-HOLE SPLICE CLEVIS FOR PW-200,210

CATALOG NUMBER	WEIGHT PER 100
PW-1345	266 Lbs (120.7 Kg)

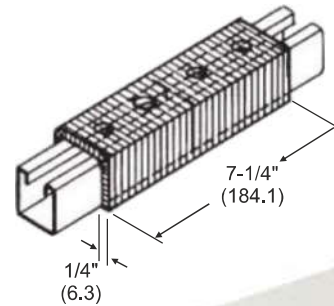

### FOUR-HOLE CLOSE ANGLES

CATALOG NUMBER	A	WEIGHT PER 100	
		lbs	kg
PW-1413	60	101	45.8
PW-1415	45	101	45.8

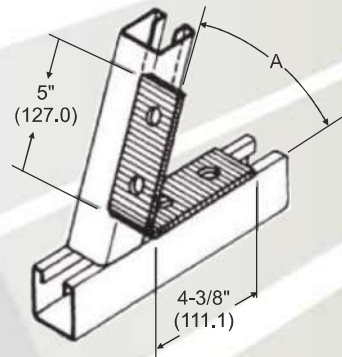

### FOUR-HOLE OPEN ANGLES

CATALOG NUMBER	A	WEIGHT PER 100	
		lbs	kg
PW-1443	60	78	35.4
PW-1445	45	78	35.4
PW-1447	30	78	35.4

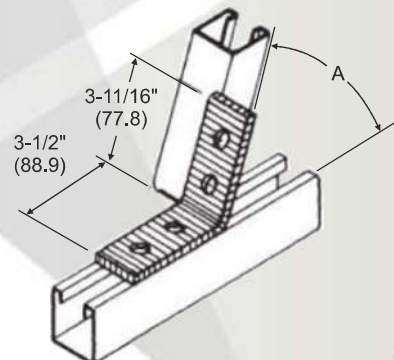

**Typical Dimensions:** Unless Otherwise shown all fittings will be as follows: Width 1-5/8" (41.3) : thickness 1/4" (6.3) : hole diameter 9/16" (14.3) : hole spacing 1-7/8" (47.6) on center and 13/16" (20.6) from end. Standard Finish: Electro-galvanized steel.

TWO-HOLE OPEN ANGLES							
CATALOG NUMBER	A	B		C		WEIGHT PER 100	
		in	mm	in	mm	lbs	kg
MOC-1423	60	3-3/8	82.7	1-7/8	47.6	58	26.3
MOC-1425	45	3	76.2	2-5/16	58.7	58	26.3
MOC-1427	45	3-1/4	82.3	2-1/16	52.4	58	26.3

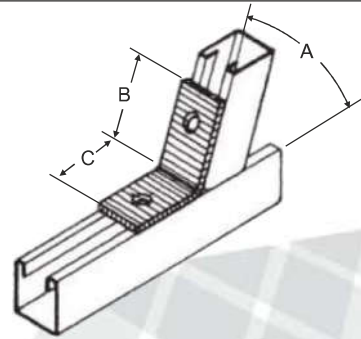

TWO-HOLE CLOSED ANGLES			
CATALOG NUMBER	A	WEIGHT PER 100	
		lbs	kg
MOC-1463	60	63	28.6
MOC-1465	45	63	28.6

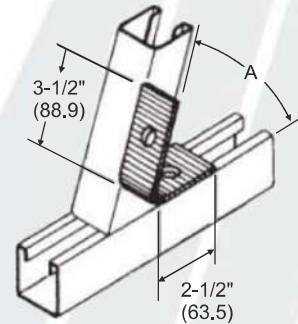

TWO-HOLE 45-DEGREE KNEE BRACES						
CATALOG NUMBER	A		B		WEIGHT PER 100	
	in	mm	in	mm	lbs	kg
MOC-1472	12	304.8	10-1/8	257.2	170	77.1
MOC-1473	16-5/8	415.9	13-3/8	339.7	230	104.3
MOC-1474	18	457.2	14-3/8	365.1	238	108.6

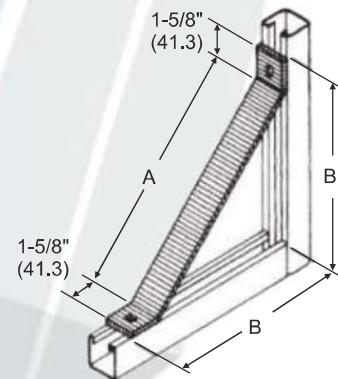

3-HOLE RIGHT HAND CORNER CONNECTOR	
CATALOG NUMBER	WEIGHT PER 100
MOSC-1510	54 Lbs (24.5 Kg)

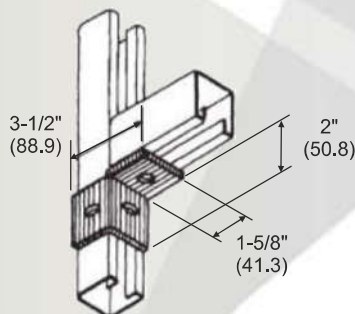

3-HOLE LEFT HAND CORNER CONNECTOR	
CATALOG NUMBER	WEIGHT PER 100
MOSC-1511	54 Lbs (24.5 Kg)

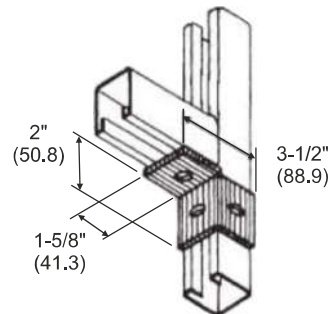

**Typical Dimensions:** Unless Otherwise shown all fittings will be as follows: Width 1-5/8" (41.3) : thickness 1/4" (6.3) : hole diameter 9/16" (14.3) : hole spacing 1-7/8" (47.6) on center and 13/16" (20.6) from end.  
Standard Finish: Electro-galvanized steel.

### 4-HOLE CORNER CONNECTOR

CATALOG NUMBER	WEIGHT PER 100
MOSC-1512	71 Lbs (32.2 Kg)

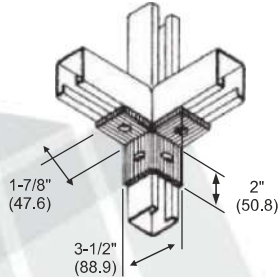

### 8-HOLE DOUBLE CORNER GUSSETED CONN.

CATALOG NUMBER	WEIGHT PER 100
MOSC-1516	196 Lbs (88.9 Kg)

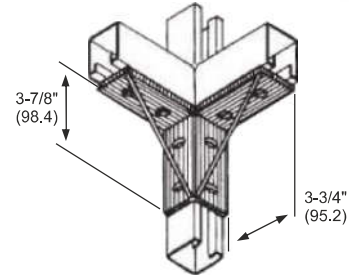

### 5-HOLE DOUBLE WING CONNECTOR

CATALOG NUMBER	WEIGHT PER 100
MOSC-1513	95 Lbs (43.1 Kg)

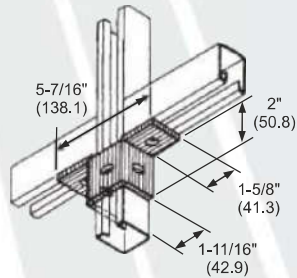

### 9-HOLE TRIPLE WING CONNECTOR

CATALOG NUMBER	WEIGHT PER 100
MOSC-1517	177 Lbs (80.3 Kg)

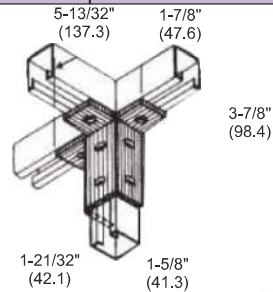

### 6-HOLE TRIPLE WING CONNECTOR

CATALOG NUMBER	WEIGHT PER 100
MOSC-1514	110 Lbs (49.9 Kg)

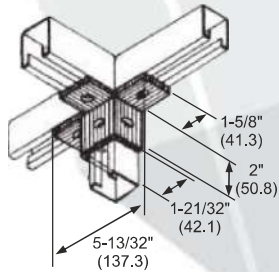

### 8-HOLE DOUBLE CORNER CONNECTOR

CATALOG NUMBER	WEIGHT PER 100
MOSC-1518	110 Lbs (49.9 Kg)

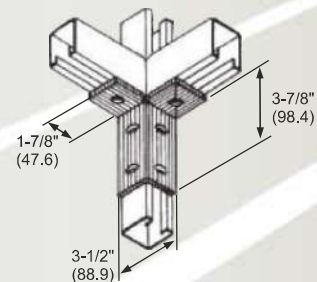

### 8-HOLE DOUBLE CORNER CONNECTOR

CATALOG NUMBER	WEIGHT PER 100
MOSC-1515	152 Lbs (68.9 Kg)

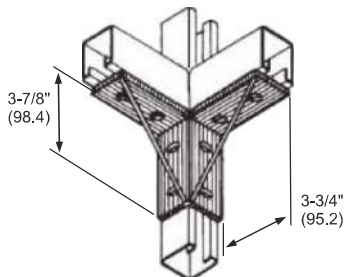

### 8-HOLE DOUBLE WING CONNECTOR

CATALOG NUMBER	WEIGHT PER 100
MOSC-1519	156 Lbs (70.8 Kg)

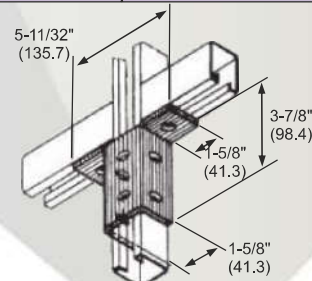

**Typical Dimensions:** Unless Otherwise shown all fittings will be as follows: Width 1-5/8" (41.3) : thickness 1/4" (6.3) : hole diameter 9/16" (14.3) : hole spacing 1-7/8" (47.6) on center and 13/16" (20.6) from end.  
**Standard Finish:** Electro-galvanized steel.

CHANNEL BRACKETS						
CATALOG NUMBER	A		WEIGHT PER 100		MOSC-200	
	in	mm	lbs	kg	Lbs	kn
MOSC-1631	6	152.4	151	68.5	1200	5.38
MOSC-1632	12	304.8	251	113.8	600	2.69
MOSC-1633	18	457.2	351	159.2	400	1.79
MOSC-1634	24	609.6	451	204.6	300	1.34

CHANNEL BRACKETS						
CATALOG NUMBER	A		WEIGHT PER 100		MOSC-200	
	in	mm	lbs	kg	Lbs	kn
MOSC-1635	6	152.4	151	68.5	720	3.23
MOSC-1636	12	304.8	251	113.8	360	1.61
MOSC-1637	18	457.2	351	159.2	240	1.07
MOSC-1638	24	609.6	451	204.6	180	0.81

CHANNEL BRACKETS						
CATALOG NUMBER	A		WEIGHT PER 100		MOSC-200	
	in	mm	lbs	kg	Lbs	kn
MOSC-1641	6	152.4	191	86.6	1600	7.17
MOSC-1642	12	304.8	292	132.4	800	3.58

CHANNEL BRACKETS						
CATALOG NUMBER	A		WEIGHT PER 100		MOSC-200	
	in	mm	lbs	kg	Lbs	kn
MOSC-1645	6	152.4	191	86.6	960	4.30
MOSC-1646	12	304.8	292	132.4	480	2.15

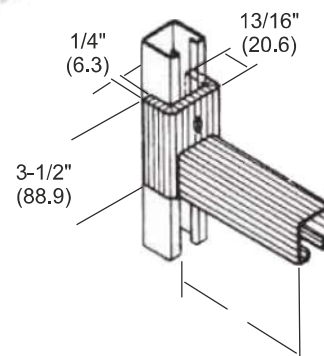
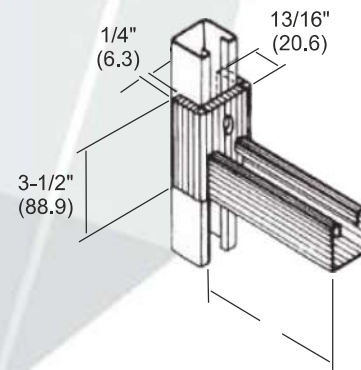
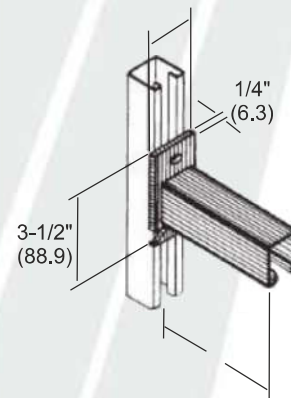
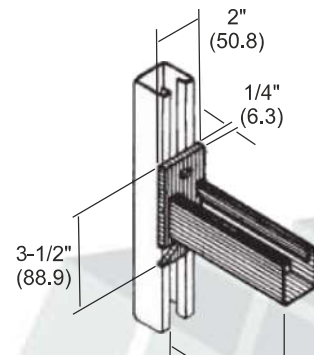

**Typical Dimensions:** Unless Otherwise shown all fittings will be as follows: Width 1-5/8" (41.3) : thickness 1/4" (6.3) : hole diameter 9/16" (14.3) : hole spacing 1-7/8" (47.6) on center and 13/16" (20.6) from end.  
Standard Finish: Electro-galvanized steel.

CHANNEL BRACKETS						
CATALOG NUMBER	A		WEIGHT PER 100		MOSC-200	
	in	mm	lbs	kg	Lbs	kn
MOSC-1647	18	457.2	436	197.8	1600	7.17
MOSC-1648	24	609.6	536	243.1	800	3.58

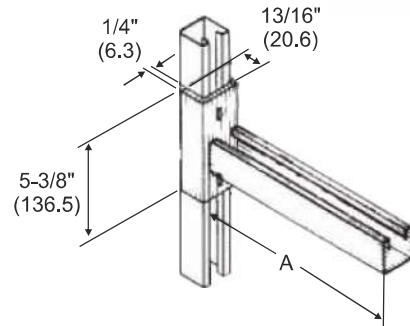

BRACKETS	
CATALOG NUMBER	WEIGHT PER 100
MOSC -1650	272Lbs (123.4 Kg)

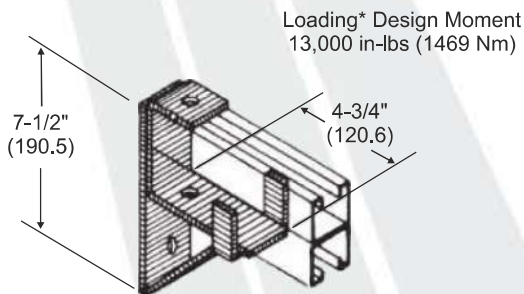

\*Applies to fitting only, not to strength of strut arm.

BRACKETS	
CATALOG NUMBER	WEIGHT PER 100
MOSC-1651	229 Lbs (103.9 Kg)

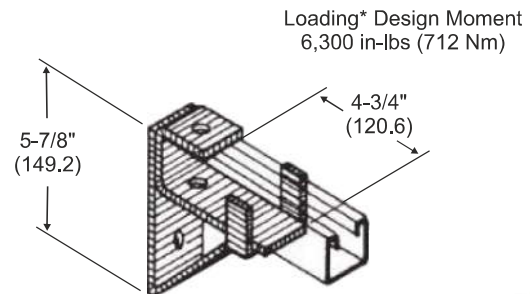

\*Applies to fitting only, not to strength of strut arm.

CHANNEL BRACKETS						
CATALOG NUMBER	A		WEIGHT PER 100		MOSC-200	
	in	mm	lbs	kg	Lbs	kn
MOSC-1652	12	304.8	514	233.1	2000	8.96
MOSC-1653	18	457.2	714	323.9	1300	8.82
MOSC-1654	24	609.6	914	414.6	1000	4.48
MOSC-1655	30	762.0	1114	505.3	800	3.58
MOSC-1656	36	914.4	1314	596.0	650	2.91

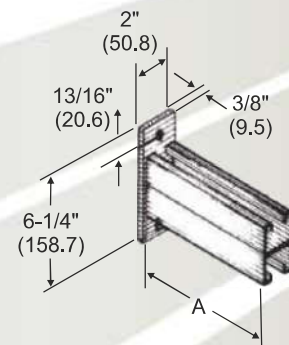

CHANNEL BRACKETS						
CATALOG NUMBER	A		WEIGHT PER 100		MOSC-200	
	in	mm	lbs	kg	Lbs	kn
MOSC-1661	6	152.4	153	69.4	1600	7.17
MOSC-1662	12	304.8	248	112.5	800	3.58
MOSC-1663	18	457.2	342	155.1	550	2.46
MOSC-1654	24	609.6	437	198.2	400	2.46

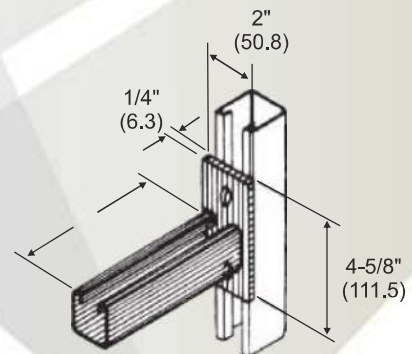

**Typical Dimensions:** Unless Otherwise shown all fittings will be as follows: Width 1-5/8" (41.3) : thickness 1/4" (6.3) : hole diameter 9/16" (14.3) : hole spacing 1-7/8" (47.6) on center and 13/16" (20.6) from end.  
Standard Finish: Electro-galvanized steel.

EIGHT-HOLE POST BASE	
CATALOG NUMBER	WEIGHT PER 100
MOSC-1811	288 Lbs (130.6Kg)

Holes in the base  
7/16" (11.1) in Diameter

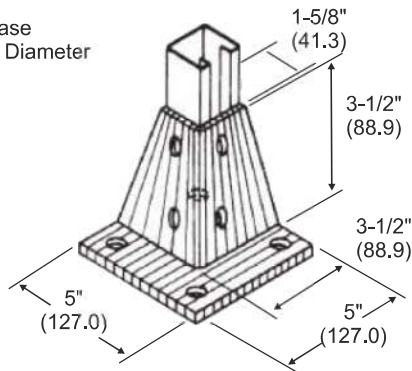

EIGHT-HOLE POST BASE	
CATALOG NUMBER	WEIGHT PER 100
MOSC-1815	330 Lbs (149.7 Kg)

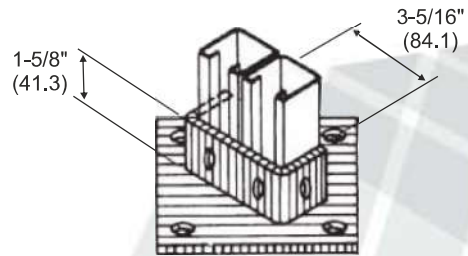

SEVEN-HOLE POST BASE	
CATALOG NUMBER	WEIGHT PER 100
MOSC-1813	314 Lbs (142.4 Kg)

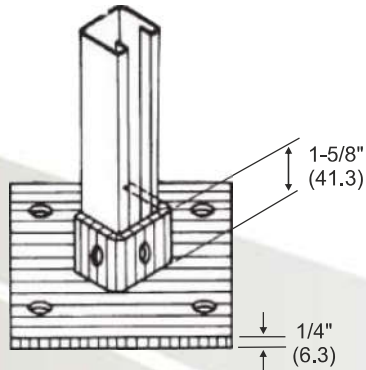

TWELVE-HOLE POST BASE	
CATALOG NUMBER	WEIGHT PER 100
MOSC-1816	400 Lbs (181.4 Kg)

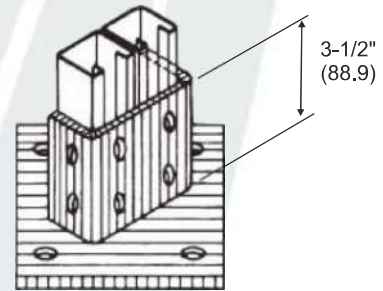

TEN-HOLE POST BASE	
CATALOG NUMBER	WEIGHT PER 100
MOSC-1814	392 Lbs (177.8 Kg)

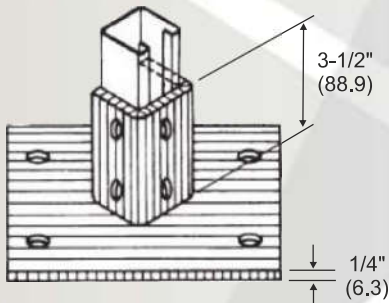

BASE PLATE	
------------	--

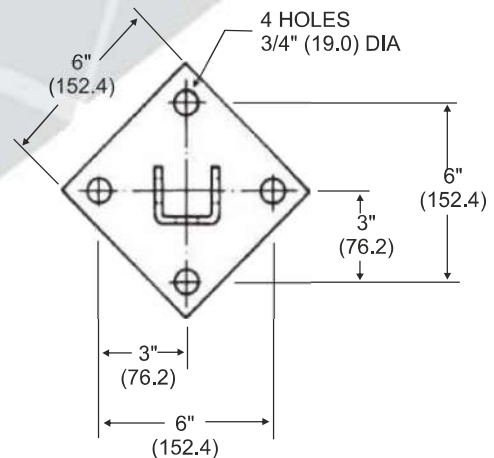

END CAP FOR MOSC-200 CHANNEL	
CATALOG NUMBER	WEIGHT PER 100
MOSC-1920	13 Lbs (5.9 Kg)



SNAP CLOSURE STRIP FOR ALL 1-5/8" WIDE CHANNELS	
CATALOG NUMBER	WEIGHT PER 100
MOSC-2500	48 Lbs (21.8 Kg)

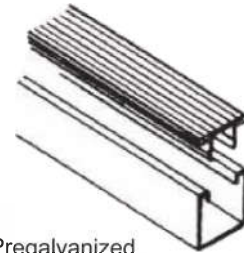

Material: 18 GA (1.2mm)  
Standard Finish: Green or Pregalvanized

ECONOMY END CAPS			
CATALOG NUMBER	CHANNEL	WEIGHT PER 100	
		lbs	kg
MOSC-1930	MOSC-200	6	2.7
MOSC-1931	MOSC-210	6	2.7
MOSC-1933	MOSC-300	5	2.3
MOSC-1935	MOSC-500	5	2.3
MOSC-1938	MOSC-800	5	2.3



END CAPS WITH KNOCK-OUTS					
CATALOG NUMBER	CONDUIT SIZE		CHANNEL	WEIGHT PER 100	
	in	mm		lbs	kg
MOSC-1940	1/2	12.7	MOSC-200	26	11.8
MOSC-1941	3/4	19.0	MOSC-200	26	11.8
MOSC-1942	1/2	12.7	MOSC-300	25	11.3
MOSC-1943	3/4	19.0	MOSC-300	25	11.3

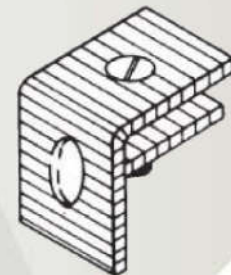

# STRUT CHANNEL SYSTEMS

## Fittings

BEAM CLAMP								
CATALOG NUMBER	A		CHANNEL HT.		WEIGHT PER 100		REC. LOAD	
	in	mm	in	mm	lbs	kg	lbs	kn
MOSC-1702	3-1/2	88.9	1-5/8	41.3	108	49.0	480	2.15
MOSC-1703	3-1/4	82.5	1-3/8	34.3	100	45.4	480	2.15
MOSC-1705	2-11/16	68.3	13/16	20.6	98	44.4	480	2.15

1/2" x 1-1/2" (12.7 x 38.1) Set Screw Included

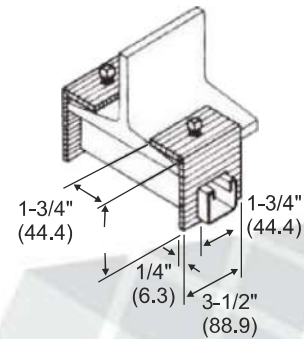

"U" BOLT BEAM CLAMP					
CATALOG NUMBER	CHANNEL	LENGTH OF "U" BOLT		WEIGHT PER 100	
		in	mm	lbs	kg
MOSC-1708	MOSC-200A	5	127.0	90	41.3
MOSC-1709	MOSC-200	3-3/8	85.7	82	37.2

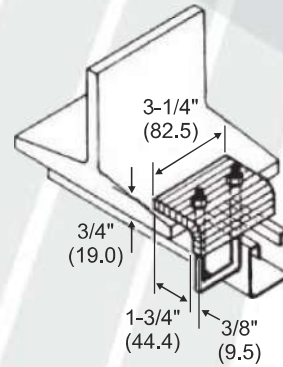

OFFSET BEAM CLAMP	
CATALOG NUMBER	CATALOG NUMBER
MOSC-1712	72 Lbs (32.7 Kg)

1/2-13 x 1-1/2"  
(12.7 x 38.1)  
Set Screw Included

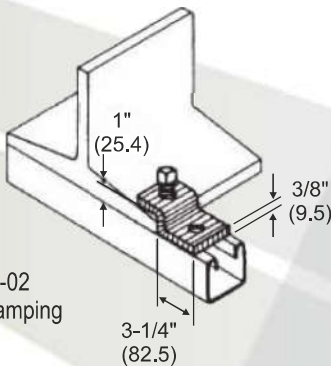

Clamp requires: DS-8547-02  
Cap screw & BSC-2-8 Clamping  
Nut (Order Separately)

TWO-HOLE BEAM CLAMP	
CATALOG NUMBER	WEIGHT PER 100
MOSC-1714	106 Lbs (48.0 Kg)

Recommended Load 1000 l.bs (4.48 kn) when used in pairs.

1/2-13 x 1-1/2"  
(12.7 x 38.1)  
Set Screw Included

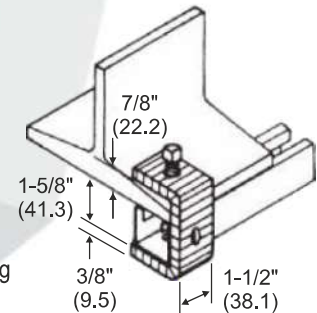

Clamp requires: DS-8547-02  
Cap screw & BSC-2-8 Clamping  
Nut (Order Separately)

ONE-HOLE BEAM CLAMP	
CATALOG NUMBER	WEIGHT PER 100
MOSC-1713	30 Lbs (13.6 Kg)

Clamp requires: DS-8547-04  
Cap screw & BSC-2-8 Clamping  
Nut (Order Separately)

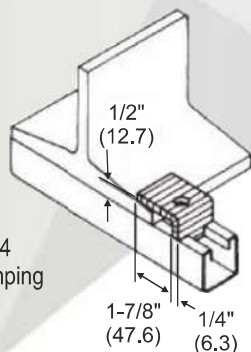

LIGHT DUTY BEAM CLAMP	
CATALOG NUMBER	WEIGHT PER 100
MOSC-1715	41 Lbs (18.6 Kg)

Recommended Load 450 Lbs (2.02 kn) when used in pairs.

3/8"-16 x 1-1/2"  
(9.5 x 38.1)  
Set Screw Included

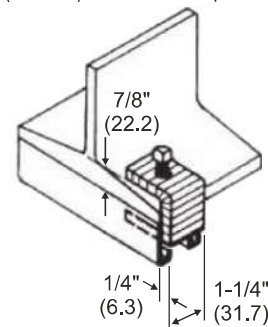

HEAVY-DUTY BEAM CLAMP	
CATALOG NUMBER	WEIGHT PER 100
MOSC-1716	60 Lbs (27.2 Kg)

Recommended Load 1000 l.bs (4.48 kn) when used in pairs.

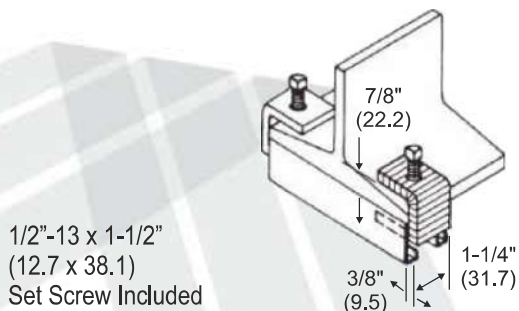

THICK-FLANGE BEAM CLAMP	
CATALOG NUMBER	WEIGHT PER 100
MOSC-1717	80 Lbs (36.3 Kg)

Recommended Load 900 l.bs (4.03 kn) when used in pairs.

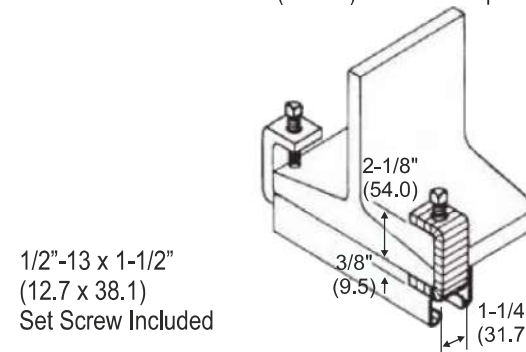

BSC-1721 through BSC-1729

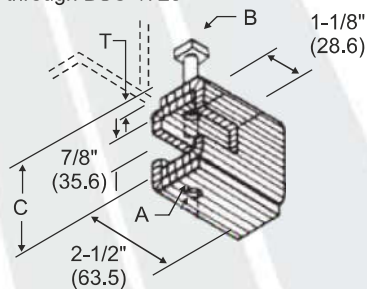

BSC-1731 through BSC-1739

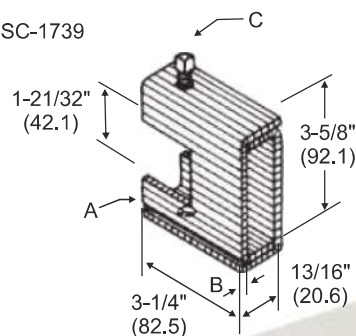

BEAM CLAMP													
CATALOG NUMBER	A		T		B		C		WEIGHT PER 100		LOAD CAPACITY		
	in	mm	in	mm	in	mm	in	mm	lbs	kg	Lbs	kn	
MOSC-1721	1/4" -20	6.3	1/8	3.2	3/8 x 1-1/2	9.5 x 38.1	2-1/2	63.5	67	30.4	650	2.91	
MOSC-1722	5/16" -18	7.9	1/8	3.2	3/8 x 1-1/2	9.5 x 38.1	2-1/2	63.5	67	30.4	650	2.91	
MOSC-1723	2/8" -16	9.5	1/8	3.2	3/8 x 1-1/2	9.5 x 38.1	2-1/2	63.5	67	30.4	650	2.91	
MOSC-1724	3/8" -16	9.5	3/16	4.8	1/2 x 1-1/2	12.7 x 38.1	2-1/2	63.5	100	45.4	1100	4.93	
MOSC-1725	1/2" -13	12.7	3/16	4.8	1/2 x 1-1/2	12.7 x 38.1	2-1/2	63.5	100	45.4	1100	4.93	
MOSC-1726	1/2" -13	12.7	1/4	6.3	1/2 x 1-1/2	12.7 x 38.1	2-1/2	63.5	130	59.0	1600	7.17	
MOSC-1727	5/8" -11	15.9	1/4	6.3	1/2 x 1-1/2	12.7 x 38.1	2-1/2	63.5	130	59.0	1600	7.17	
MOSC-1728	5/8" -11	15.9	5/16	7.9	5/8 x 1-1/2	15.9 x 38.1	2-1/2	63.5	160	72.6	2400	10.75	
MOSC-1729	3/4" -11	19.0	5/16	7.9	5/8 x 1-1/2	15.9 x 38.1	2-1/2	63.5	160	72.6	2400	10.75	

BEAM CLAMP													
CATALOG NUMBER	A		B		C		WEIGHT PER 100		LOAD CAPACITY				
	in	mm	in	mm	in	mm	lbs	kg	Lbs	kn			
MOSC-1731	1/4" -20	6.3	1/8	3.2	3/8 x 2	9.5 x 50.8	105	47.6	800	3.58			
MOSC-1732	5/16" -18	7.9	1/8	3.2	3/8 x 2	9.5 x 50.8	105	47.6	800	3.58			
MOSC-1733	3/8" -16	9.5	1/8	3.2	3/8 x 2	9.5 x 50.8	105	47.6	800	3.58			
MOSC-1734	3/8" -16	9.5	3/16	4.8	1/2 x 2	12.7 x 50.8	160	72.6	1300	5.82			
MOSC-1735	1/2" -13	12.7	3/16	4.8	1/2 x 2	12.7 x 50.8	160	72.6	1300	5.82			
MOSC-1736	1/2" -13	12.7	1/4	6.3	1/2 x 2	12.7 x 50.8	200	90.7	1300	8.51			
MOSC-1737	5/8" -11	15.9	1/4	6.3	1/2 x 2	12.7 x 50.8	200	90.7	1900	8.51/1			
MOSC-1738	5/8" -11	15.9	5/16	7.9	5/8 x 2	15.9 x 50.8	250	113.4	2800	12.54			
MOSC-1739	3/4" -10	19.0	5/16	7.9	5/8 x 2	15.9 x 50.8	250	113.4	2800	12.54			

# STRUT CHANNEL SYSTEMS

## Channel Nuts & Hardware

### HEX Nuts



Thread Size	Zinc Plated	Hot Dip Galvanised	Stainless Steel
M6	HN6Z	HN6H	HN6S
M8	HN8Z	HN8H	HN8S
M10	HN10Z	HN10H	HN10S
M12	HN12Z	HN12H	HN12S
M16	HN16Z	–	–

### Spring Washer



Thread Size	Zinc Plated	Hot Dip Galvanised	Stainless Steel
M6	SW6Z	SW6H	SW6S
M8	SW8Z	SW8H	SW8S
M10	SW10Z	SW10H	SW10S
M12	SW12Z	SW12H	SW12S
M16	SW16Z	–	–

### Flat Washer



Thread Size	Zinc Plated	Hot Dip Galvanised	Stainless Steel
M6	FW6Z	FW6H	FW6S
M8	FW8Z	FW8H	FW8S
M10	FW10Z	FW10H	FW10S
M12	FW12Z	FW12H	FW12S
M16	FW16Z	–	–

### Mud Guard Washer



Thread Size	Zinc Plated	Hot Dip Galvanised	Stainless Steel
M6	MW6Z	MW6H	–
M8	MW8Z	–	–
M10	MW10Z	–	–
M12	MW12Z	–	–

### HEX SCREWS

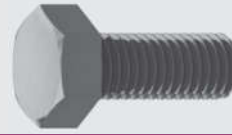

Thread Size	Length (mm)	Zinc Plated	Hot Dip Galvanised	Stainless Steel
M6	20	HS620Z	HS620H	HS620S
	25	HS625Z	–	HS625S
	30	HS630Z	–	HS630S
	40	HS640Z	–	HS640S
M8	20	HS820Z	HS820H	HS820S
	25	HS825Z	HS825H	HS825S
	30	HS830Z	HS830H	HS830S
	40	HS840Z	HS840H	HS840S
M10	20	HS1020Z	HS1020H	HS1020S
	25	HS1025Z	HS1025H	HS1025S
	30	HS1030Z	HS1030H	HS1030S
	40	HS1040Z	HS1040H	HS1040S
M12	25	HS1225Z	HS1225H	HS1225S
	30	HS1230Z	HS1230H	HS1230S
	40	HS1240Z	HS1240H	HS1240S
	50	HS1250Z	HS1250H	HS1250S

### PAN SCREWS



Thread Size	Length (mm)	Zinc Plated	Hot Dip Galvanised	Stainless Steel
M6	16	PS616Z	–	–
M6	20	PS620Z	PS620H	–
M6	25	PS625Z	–	–
M8	25	PS825Z	–	–

### COUNTERSUNK SET SCREWS



Thread Size	Length (mm)	Zinc Plated	Hot Dip Galvanised	Stainless Steel
M6	16	CS616Z	–	–
M6	20	CS620Z	–	–
M6	25	CS625Z	–	–
M8	20	CS820Z	–	–
M8	25	CS825Z	–	–

# STRUT CHANNEL SYSTEMS

## Channel Nuts & Hardware

**SBH & CNH** Wt: 0.03kg



**ORDERING DETAILS**  
Both items are ordered separately.

Metalone Splice Bolts have a smooth head to eliminate the risk of sheathing the cable during installation.

Purpose made Counterbore Nuts ensure that full tension is achieved during installation.

Specify MTF KH when both parts are required.  
MTF KH supplied in packs of 40.  
Hot Dip Galvanised.

**SB & SN** Wt: 0.03kg



**ORDERING DETAILS**  
Both items are ordered separately.

Metalone Splice Bolts have a smooth head to eliminate the risk of sheathing the cable during installation.

<b>AVAILABLE FINISH</b>	<b>ORDERING CODE</b>
Hot Dip Galvanised	SBH/SNH
Stainless Steel	SBS/SNS

**THREADED ROD**



Sold in 3m lengths

Thread Size	Zinc Plated	Hot Dip Galvanised	Stainless Steel
M6	TR6Z	–	–
M8	TR8Z	–	–
M10	TR10Z	TR10H	TR10S
M12	TR12Z	TR12H	TR12S
M16	TR16Z	–	–

**ROD COUPLER**



Sold in 3m lengths

Thread Size	Zinc Plated	Hot Dip Galvanised	Stainless Steel
M6	RC6Z	–	–
M8	RC8Z	–	–
M10	RC10Z	RC10H	RC10S
M12	RC12Z	RC12H	RC12S
M16	RC16Z	–	–

**THREADED ROD CUTTER**



<b>MTRCM10</b>	M10 Threaded Rod Cutter
<b>M10RB</b>	M6, M8, M10 Replacement Blades
<b>MTRCM12</b>	M12 Threaded Rod Cutter
<b>M12RB</b>	M10, M12 Replacement Blades

**LIPPED DROP IN ANCHORS**



Thread Size	Zinc Plated	Size (mm)
M8	LPDM10	30
M10	LPDM20	50

# STRUT CHANNEL SYSTEMS

## Channel Nuts & Hardware

### CHANNEL NUT WITH LONG SPRING



Suits all 41mm high channel

Thread Size	Zinc Plated	Hot Dip Galvanised	Stainless Steel
M6	M1006Z	M1006H	M1006S
M8	M1007Z	M1007H	M1007S
M10	M1008Z	M1008H	M1008S
M12	M1010Z	M1010H	M1010S

### CHANNEL NUT WITH SHORT SPRING



Suits all 21mm high channel

Thread Size	Zinc Plated	Hot Dip Galvanised	Stainless Steel
M6	M4006Z	M4006H	—
M8	M4007Z	M4007H	—
M10	M4008Z	M4008H	—
M12	M4010Z	M4010H	—

### CHANNEL NUT WITH NO SPRING



Suits all channel

Thread Size	Zinc Plated	Hot Dip Galvanised	Stainless Steel
M6	M3006Z	M3006H	—
M8	M3007Z	M3007H	—
M10	M3008Z	M3008H	—
M12	M3010Z	M3010H	—

### NARROW CHANNEL NUT NO SPRING



Suits all channel

Thread Size	Zinc Plated	Hot Dip Galvanised	Stainless Steel
M6	M3016Z	M3016H	M3016S
M8	—	—	—
M10	—	—	—
M12	—	—	—

### SLOTTED ANGLE



#### ORDERING

Code	Material	Slot
MF2500	25 x 25 x 3	25 x 11
MF3000	30 x 30 x 3	25 x 14
MF5000	50 x 50 x 3	24 x 14
MF5005	50 x 50 x 5	24 x 14

### ANGLE

#### ORDERING

Code	Material
MF1510-30/2.5	30 x 30 x 2.5
MF1510-40/2.5	40 x 40 x 2.5
MF1510-40/4.0	40 x 40 x 4.0
MF1510-50/4.0	50 x 50 x 4.0
MF1510-50/5.0	50 x 50 x 5.0
MF1510-65/4.0	65 x 65 x 4.0
MF1510-65/5.0	65 x 65 x 5.0
MF1510-75/4.0	75 x 75 x 4.0
MF1510-75/5.0	75 x 75 x 5.0

SLIP & PULL OUT PERFORMANCE				
Channel Type	Spring Nut	Pullout (kg)	Torque (Nm)	Slip (kg)
<b>M1000</b>	M1006 M6	577	180	3.5
	M1007 M8	895	195	8.5
	M1008 M10	1050	260	17.0
	M1010 M12	1680	390	30.0
<b>M3300</b>	M4006 M6	577	180	3.5
	M4007 M8	895	195	8.5
	M4008 M10	1050	260	17.0
	M4010 M12	1680	390	30.0
<b>M5500</b>	M3008 M10	1050	260	17.0
	M3010 M12	1680	390	30.0

Pullout and Slip load information has been derived from actual testing, carried out in a certified testing facility.

All test results were conducted using the standard range of Metalone products, with grade 4.6 commercial screws.

Using limit state design techniques, the published results are ultimate loads and consideration must be given to the required safety factor, based on the intended application.

The torque values shown are as prescribed by fastener manufacturers and tension should be applied using a calibrated torque wrench during the installation process.

Greater capacity loads can be achieved using non standard products, such as grade 8.8 screws. Consult your nearest sales office for advice on special installation requirements.

# STRUT CHANNEL SYSTEMS

## Mechanical Accessories

THINWALL CONDUIT (EMT) CLAMP							
CATALOG NUMBER	NORMAL SIZE		WEIGHT PER 100		GAGE	SLOTTED HEX CAP SCREW	
	in	mm	lbs	kg		in	mm
MOSC-2025	3/8	9.5	9	4.1	16	1/4 x 3/4	6.3 x 19.0
MOSC-2026	1/2	12.7	11	5.0	16	1/4 x 3/4	6.3 x 19.0
MOSC-2028	3/4	19.0	12	5.4	16	1/4 x 3/4	6.3 x 19.0
MOSC-2030	1	25.4	15	6.8	14	1/4 x 3/4	6.3 x 19.0
MOSC-2032	1-1/4	31.7	18	8.2	14	1/4 x 3/4	6.3 x 19.0
MOSC-2034	1-1/2	38.1	29	13.1	12	5/16 x 1	7.9 x 25.4
MOSC-2038	2	50.8	33	15.0	12	5/16 x 1	7.9 x 25.4

Includes Slotted Indented Hex Head Cap Screw and Kep Nut.

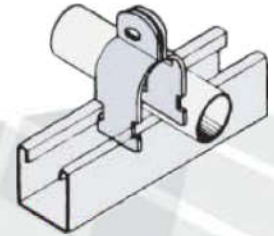

UNIVERSAL CLAMP SERIES							
CATALOG NUMBER	NORMAL SIZE		WEIGHT PER 100		GAGE	SLOTTED HEX CAP SCREW	
	in	mm	lbs	kg		in	mm
MOSC-2055	3/8	9.5	9	4.1	16	5/16 x 1-1/4	7.9 x 31.7
MOSC-2056	1/2	12.7	11	5.0	16	5/16 x 1-1/4	7.9 x 31.7
MOSC-2058	3/4	19.0	12	5.4	16	5/16 x 1-1/4	7.9 x 31.7
MOSC-2060	1	25.4	15	6.8	14	5/16 x 1-1/4	7.9 x 31.7
MOSC-2062	1-1/4	31.7	18	8.2	14	5/16 x 1-1/4	7.9 x 31.7
MOSC-2064	1-1/2	38.1	29	13.1	12	5/16 x 1-1/4	7.9 x 31.7
MOSC-2068	2	50.8	33	15.0	12	5/16 x 1-1/4	7.9 x 31.7

Includes Slotted Indented Hex Head Cap Screw and Kep Nut.

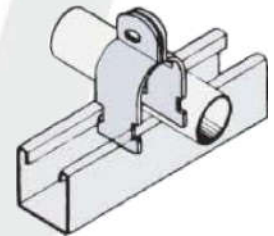

RIGID CONDUIT OR PIPE CLAMPS							
CATALOG NUMBER	NORMAL SIZE		WEIGHT PER 100		GAGE	SLOTTED HEX CAP SCREW	
	in	mm	lbs	kg		in	mm
MOSC-2125	3/8	9.5	10	4.5	16	1/4 x 3/4	6.3 x 19.0
MOSC-2126	1/2	12.7	11	5.0	16	1/4 x 3/4	6.3 x 19.0
MOSC-2128	3/4	19.0	15	6.8	14	1/4 x 3/4	6.3 x 19.0
MOSC-2130	1	25.4	17	7.7	14	1/4 x 3/4	6.3 x 19.0
MOSC-2132	1-1/4	31.7	19	8.6	14	1/4 x 3/4	6.3 x 19.0
MOSC-2134	1-1/2	38.1	29	13.1	12	2/16 x 1	7.9 x 25.4
MOSC-2138	2	50.8	34	15.4	12	2/16 x 1	7.9 x 25.4
MOSC-2142	2-1/2	63.5	40	18.1	12	5/16 x 1	7.9 x 25.4
MOSC-2146	3	76.2	47	21.3	12	5/16 x 1	7.9 x 25.4
MOSC-2150	3-1/2	88.9	62	28.1	11	3/8 x 1	9.5 x 25.4
MOSC-2154	4	101.6	67	30.4	11	3/8 x 1-1/4	9.5 x 25.4
MOSC-2162	5	127.0	80	36.3	11	3/8 x 1-1/4	9.5 x 31.7
MOSC-2170	6	152.4	102	46.3	10	3/8 x 1-1/4	9.5 x 31.7
MOSC-2174	8	203.2	116	52.6	10	3/8 x 1-1/4	9.5 x 31.7

Includes Slotted Indented Hex Head Cap Screw and Kep Nut.

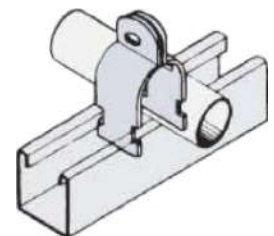

# STRUT CHANNEL SYSTEMS

## Mechanical Accessories

O.D. TUBING CLAMPS							
CATALOG NUMBER	NORMAL SIZE		WEIGHT PER 100		GAGE	SLOTTED HEX CAP SCREW	
	in	mm	lbs	kg		in	mm
MOSC-2224	1/4	6.3	8	3.6	16	1/4 x 3/4	6.3 x 19.0
MOSC-2225	3/8	9.5	8	3.6	16	1/4 x 3/4	6.3 x 19.0
MOSC-2226	1/2	12.7	9	4.1	16	1/4 x 3/4	6.3 x 19.0
MOSC-2227	5/8	15.9	10	4.5	16	1/4 x 3/4	6.3 x 19.0
MOSC-2228	3/4	19.0	11	5.0	16	1/4 x 3/4	6.3 x 19.0
MOSC-2229	7/8	22.2	12	5.4	16	1/4 x 3/4	6.3 x 19.0
MOSC-2230	1	25.4	12	6.3	16	1/4 x 3/4	6.3 x 19.0
MOSC-2231	1-1/8	28.6	15	6.8	14	1/4 x 3/4	6.3 x 19.0
MOSC-2232	1-1/4	31.7	16	7.3	14	1/4 x 3/4	6.3 x 19.0
MOSC-2233	1-3/8	34.9	17	7.7	14	1/4 x 3/4	6.3 x 19.0
MOSC-2234	1-1/2	38.1	18	8.2	14	1/4 x 3/4	6.3 x 19.0
MOSC-2235	1-5/8	41.3	19	8.6	14	1/4 x 3/4	6.3 x 19.0
MOSC-2234	1-3/4	44.4	29	13.1	12	5/16 x 1	7.9 x 25.4
MOSC-2237	1-7/8	47.6	28	12.7	12	5/16 x 1	7.9 x 25.4
MOSC-2238	2	50.8	31	14.1	12	5/16 x 1	7.9 x 25.4
MOSC-2239	2-1/8	54.0	32	14.5	12	5/16 x 1	7.9 x 25.4
MOSC-2240	2-1/4	57.1	33	15.0	12	5/16 x 1	7.9 x 25.4
MOSC-2238	2-3/8	60.3	34	15.4	12	5/16 x 1	7.9 x 25.4
MOSC-2242	2-1/2	63.5	35	15.9	12	5/16 x 1	7.9 x 25.4
MOSC-2243	2-5/8	66.7	37	16.8	12	5/16 x 1	7.9 x 25.4
MOSC-2244	2-5/4	69.9	38	17.2	12	5/16 x 1	7.9 x 25.4
MOSC-2242	2-7/8	73.0	40	18.1	12	5/16 x 1	7.9 x 25.4
MOSC-2246	3	76.2	41	18.6	12	5/16 x 1	7.9 x 25.4
MOSC-2247	3-1/8	79.4	43	19.5	12	5/16 x 1	7.9 x 25.4
MOSC-2248	3-1/4	82.6	45	20.4	12	5/16 x 1	7.9 x 25.4
MOSC-2249	3-3/8	85.7	46	20.9	2	5/16 x 1	7.9 x 25.4
MOSC-2246	3-1/2	88.9	47	21.3	2	5/16 x 1	7.9 x 25.4
MOSC-2251	3-5/8	92.1	56	25.4	11	3/8 x 1-1/4	9.5 x 31.7
MOSC-2252	3-3/4	95.3	58	26.3	11	3/8 x 1-1/4	9.5 x 31.7
MOSC-2253	3-7/8	98.4	60	27.2	11	3/8 x 1-1/4	9.5 x 31.7
MOSC-2250	4	101.6	62	28.1	11	3/8 x 1-1/4	9.5 x 31.7
MOSC-2255	4-1/8	104.6	62	28.1	11	3/8 x 1-1/4	9.5 x 31.7
MOSC-2256	4-1/4	108.0	64	29.0	11	3/8 x 1-1/4	9.5 x 31.7
MOSC-2257	4-3/8	111.1	66	29.9	11	3/8 x 1-1/4	9.5 x 31.7
MOSC-2254	4-1/2	114.3	67	30.4	11	3/8 x 1-1/4	9.5 x 31.7
MOSC-2259	4-5/8	117.5	70	31.7	11	3/8 x 1-1/4	9.5 x 31.7
MOSC-2260	4-3/4	120.6	72	32.7	11	3/8 x 1-1/4	9.5 x 31.7
MOSC-2261	4-7/8	123.8	73	33.1	11	3/8 x 1-1/4	9.5 x 31.7
MOSC-2262	5	127.0	74	33.6	11	3/8 x 1-1/4	9.5 x 31.7
MOSC-2263	5-1/8	130.2	76	34.6	11	3/8 x 1-1/4	9.5 x 31.7
MOSC-2264	5-1/4	133.3	77	34.9	11	3/8 x 1-1/4	9.5 x 31.7
MOSC-2262	5-3/8	136.5	78	35.4	11	3/8 x 1-1/4	9.5 x 31.7
MOSC-2266	5-1/2	139.7	79	35.8	11	3/8 x 1-1/4	9.5 x 31.7
MOSC-2267	5-5/8	142.9	88	39.9	10	3/8 x 1-1/4	9.5 x 31.7
MOSC-2268	5-3/1	146.0	90	40.8	10	3/8 x 1-1/4	9.5 x 31.7
MOSC-2269	5-7/1	149.2	92	41.7	10	3/8 x 1-1/4	9.5 x 31.7
MOSC-2270	6	152.4	92	41.7	10	3/8 x 1-1/4	9.5 x 31.7

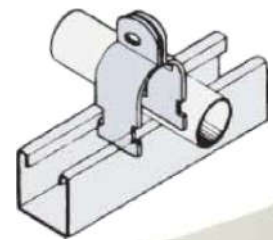

Includes Slotted Hex Head Cap Screw and Kep Nut.

ONE-HOLE O.D. TUBING CLAMPS				
CATALOG NUMBER	O.D. TUBE SIZE		WEIGHT PER 100	
	in	mm	lbs	kg
MOSC-3724	1/4	6.3	4	1.8
MOSC-3724A	5/16	7.9	5	2.3
MOSC-3725	3/8	9.5	5	2.3
MOSC-3726	1/2	12.7	6	2.7
MOSC-3727	5/8	15.9	8	3.6
MOSC-3728	3/4	19.0	9	4.1
MOSC-3729	7/8	22.2	10	4.5
MOSC-3730	1	25.4	11	5.0

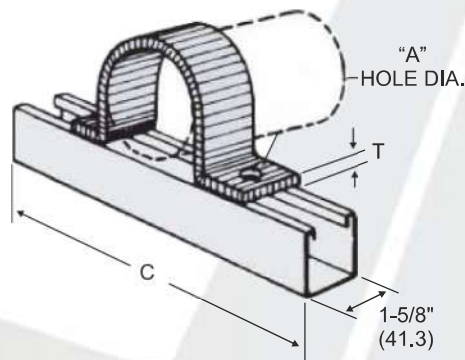
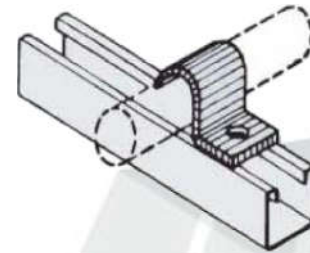

STANDARD PIPE STRAPS										
CATALOG NUMBER	PIPE SIZE		"C" LENGTH		"T" THICKNESS		"A" HOLE SIZE		WEIGHT PER 100	
	in	mm	in	mm	in	mm	in	mm	lbs	kg
MOSC-3826	1/2	12.7	3	76.2	1/8	3.2	9/32	7.1	24	10.9
MOSC-3828	3/4	19.0	3-1/4	82.6	1/8	3.2	9/32	7.1	28	12.7
MOSC-3830	1	25.4	3-9/16	90.5	1/8	3.2	9/32	7.1	32	14.5
MOSC-3832	1-1/4	31.7	3-12/16	96.8	1/8	3.2	9/32	7.1	35	15.9
MOSC-3834	1-1/2	38.1	4-1/16	103.2	1/8	3.2	9/32	7.1	40	18.1
MOSC-3838	2	50.8	5-13/16	147.6	1/8	6.3	7/16	11.1	95	43.1
MOSC-3842	2-1/2	63.5	6-1/4	158.7	1/4	6.3	7/16	11.1	116	52.6
MOSC-3846	3	76.2	7	177.8	1/4	6.3	7/16	11.1	135	61.2
MOSC-3850	3-1/2	88.9	7-7/8	200.0	1/4	6.3	7/16	11.1	155	70.3
MOSC-3854	4	101.6	8	203.2	1/4	6.3	7/16	11.1	180	81.6
MOSC-3862	5	127.0	9-1/8	231.8	1/4	6.3	7/16	11.1	195	88.4
MOSC-3870	5	152.4	10-5/16	261.9	1/4	6.3	7/16	11.1	240	108.9

### PROPERTIES OF SECTIONS:

- I = Moment of Inertia
- S = Section Modulus
- R = Radius of Gyration
- Wt. = Weight
- Area = Cross Sectional Area

### STANDARD LENGTHS:

10 ft (3.05 m) & 20 ft (6.09 m)

### STANDARD FINISH:

Mill-galvanized per ASTM A-653.

### BEAM AND COLUMN DATA:

**Uniform Load:** Load shown is total load uniformly distributed over a simple span. Stress level is 25,000 psi (172MPa) and is recommended for use where deflection is not critical.

**Uniform Load at Deflection = 1/240 Span:** Load shown is total load uniformly distributed over a simple span. this load is recommended for use where deflection is required to be unnotiveable.

**Maximum Column Loading:** Load shown is total allowable axial load. For eccentric loads, reduce values shown accordingly.

For allowable concentrated load at center of span, multiply load shown by 0.5 and deflection shown by 0.8.

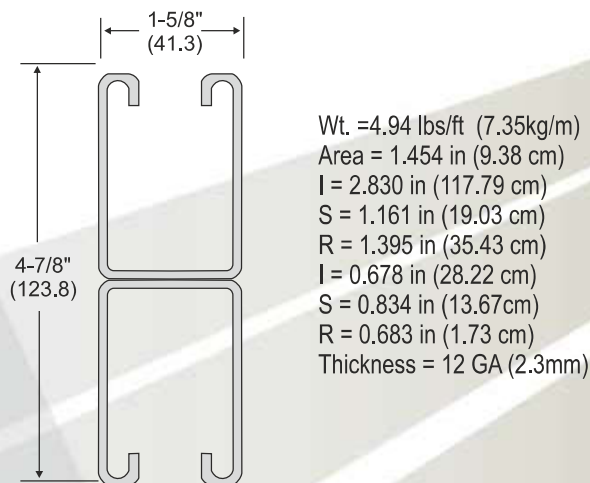
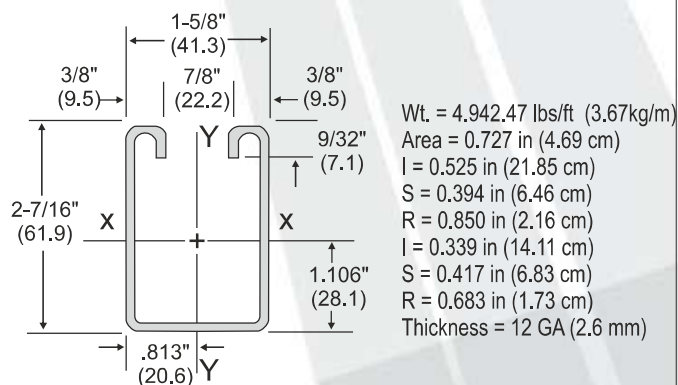

MOSC-100 CHANNEL							
BEAM SPAN OR COLUMN HT.	in mm	UNIFORM LOAD		UNIFORM LOAD AT DEFLECTION =1/240 SPAN		MAXIMUM COLUMN LOAD	
		lbs	kn	lbs	kn	lbs	kn
24	610	3283	14.71	3283	14.71	8319	37.27
36	914	2188	9.80	2188	9.80	7139	31.98
48	1219	1+41	7.35	1641	7.35	5747	25.75
60	1524	1313	5.88	1313	5.88	4306	19.29
72	1829	1094	4.90	972	4.35	3345	14.99
84	2134	938	4.20	714	3.20	2746	12.30
96	2438	820	3.67	546	2.45	2340	10.48
108	2743	729	3.27	432	1.94	2043	9.15
120	3048	656	2.94	350	1.57	1817	8.14

BSC-100A CHANNEL							
BEAM SPAN OR COLUMN HT.	in mm	UNIFORM LOAD		UNIFORM LOAD AT DEFLECTION =1/240 SPAN		MAXIMUM COLUMN LOAD	
		lbs	kn	lbs	kn	lbs	kn
24	610	3800	17.02	3800	17.02	18467	82.73
36	914	3800	17.02	3800	17.02	18015	80.71
48	1219	3800	17.02	3800	17.02	17383	77.88
60	1524	3800	17.02	3800	17.02	16570	74.23
72	1829	3225	14.95	3225	14.95	15578	66.79
84	2134	2764	12.38	2764	12.38	14404	64.53
96	2438	2418	10.83	2410	10.83	13050	58.46
108	2743	2150	9.63	2150	9.63	11515	51.59
120	3048	1935	8.67	1886	8.45	9800	43.90

\* Limited by spot weld shear.

# STRUT CHANNEL SYSTEMS

## Engineering Data

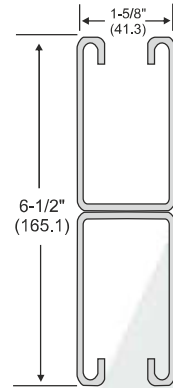
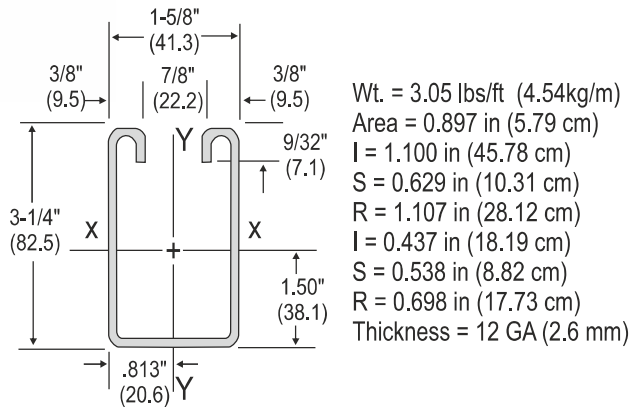

Wt. = 6.10 lbs/ft (7.08kg/m)  
 Area = 1.794 in (11.57 cm)  
 I = 6.225 in (259.10 cm)  
 S = 1.915 in (31.39 cm)  
 R = 1.863 in (47.32 cm)  
 I = 0.874 in (36.38 cm)  
 S = 1.076 in (17.64 cm)  
 R = 0.698 in (17.73 cm)  
 Thickness = 12 GA (2.6mm)

MOSC-150 CHANNEL							
BEAM SPAN OR COLUMN HT.		UNIFORM LOAD		UNIFORM LOAD AT DEFLECTION =1/240 SPAN		MAXIMUM COLUMN LOAD	
in	mm	lbs	kn	lbs	kn	lbs	kn
24	610	5241	23.48	5241	23.48	7371	33.02
36	914	3494	15.65	3494	15.65	6579	29.47
48	1219	2620	11.74	2620	11.74	5592	25.05
60	1524	2096	9.39	2096	9.39	4489	20.11
72	1829	1747	7.83	1747	7.83	3484	15.61
84	2134	1497	6.71	1496	6.70	2756	12.35
96	2438	1310	5.87	1145	5.13	2307	10.33
108	2743	1164	5.21	905	4.05	1991	8.92
120	3048	1048	4.69	733	3.28	1757	7.87

MOSC-150 CHANNEL							
BEAM SPAN OR COLUMN HT.		UNIFORM LOAD		UNIFORM LOAD AT DEFLECTION =1/240 SPAN		MAXIMUM COLUMN LOAD	
in	mm	lbs	kn	lbs	kn	lbs	kn
24	610	4900	21.95	4900	21.95	15930	71.37
36	914	4900	21.95	4900	21.95	15674	70.22
48	1219	4900	21.95	4900	21.95	15314	68.61
60	1524	4900	21.95	4900	21.95	14852	66.54
72	1829	4900	21.95	4900	21.95	14852	66.54
84	2134	4559	20.42	4559	20.42	13621	61.02
96	2438	3989	17.87	3989	17.87	12851	57.57
108	2743	3546	15.89	3546	15.89	11979	53.67
120	3048	3191	14.30	3191	14.30	11003	49.29

\* Limited by spot weld shear.

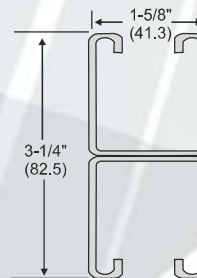
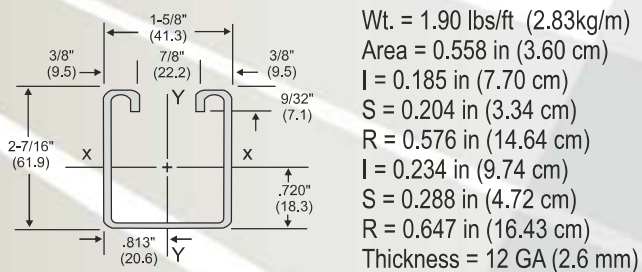

Wt. = 3.80 lbs/ft (5.65kg/m)  
 Area = 1.116 in (7.20 cm)  
 I = 0.940 in (39.12 cm)  
 S = 0.578 in (9.47 cm)  
 R = 0.918 in (23.32 cm)  
 I = 0.468 in (19.48cm)  
 S = 0.576 in (9.44 cm)  
 R = 0.647 in (16.43 cm)  
 Thickness = 12 GA (2.6mm)

MOSC-200 CHANNEL							
BEAM SPAN OR COLUMN HT.		UNIFORM LOAD		UNIFORM LOAD AT DEFLECTION =1/240 SPAN		MAXIMUM COLUMN LOAD	
in	mm	lbs	kn	lbs	kn	lbs	kn
24	610	1700	7.62	1700	7.62	8370	37.50
36	914	1133	5.08	1133	5.08	7020	31.45
48	1219	850	3.81	772	3.46	5573	24.97
60	1524	680	3.05	494	2.21	4246	19.02
72	1829	566	2.54	343	1.54	3411	15.28
84	2134	485	2.17	252	1.13	2858	12.80
96	2438	425	1.90	193	0.86	2455	11.00
108	2743	377	1.69	152	0.68	2142	9.60
120	3048	340	1.52	123	0.55	1890	8.47

MOSC-200A CHANNEL							
BEAM SPAN OR COLUMN HT.		UNIFORM LOAD		UNIFORM LOAD AT DEFLECTION =1/240 SPAN		MAXIMUM COLUMN LOAD	
in	mm	lbs	kn	lbs	kn	lbs	kn
24	610	2480	11.11	2480	11.11	19047	85.33
36	914	2480	11.11	2480	11.11	18357	82.24
48	1219	2408	10.79	2408	10.79	17389	77.90
60	1524	1926	8.63	1926	8.63	16146	72.33
72	1829	1605	7.19	1605	7.19	14625	65.52
84	2134	1376	6.16	1278	5.72	12829	57.47
96	2438	1204	5.39	979	4.39	10755	48.18
108	2743	1070	4.79	773	3.46	8571	38.40
120	3048	963	4.31	626	2.80	6943	31.10

\* Limited by spot weld shear.

# STRUT CHANNEL SYSTEMS

## Engineering Data

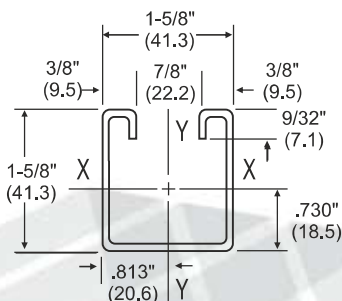

Wt. = 1.40 lbs/ft (2.08 kg/m)  
 Area = 0.412 in (2.66 cm)  
 I = 0.146 in (6.08 cm)  
 S = 0.163 in (2.67 cm)  
 R = 0.595 in (15.11 cm)  
 I = 0.180 in (7.49 cm)  
 S = 0.222 in (3.64 cm)  
 R = 0.661 in (16.79 cm)  
 Thickness = 14 GA (1.9 mm)

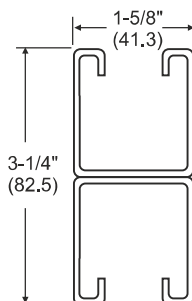

Wt. = 2.80 lbs/ft (4.17kg/m)  
 Area = 0.824 in (5.31 cm)  
 I = 0.730 in (30.38 cm)  
 S = 0.449 in (7.36 cm)  
 R = 0.941 in (23.90 cm)  
 I = 0.360 in (14.98 cm)  
 S = 0.444 in (7.28 cm)  
 R = 0.661 in (16.79 cm)  
 Thickness = 14 GA (1.9 mm)

MOSC-210 CHANNEL							
BEAM SPAN OR COLUMN HT.		UNIFORM LOAD		UNIFORM LOAD AT DEFLECTION =1/240 SPAN		MAXIMUM COLUMN LOAD	
in	mm	lbs	kn	lbs	kn	lbs	kn
24	610	1700	7.62	1700	7.62	8370	37.50
36	914	1133	5.08	1133	5.08	7020	31.45
48	1219	850	3.81	772	3.46	5573	24.97
60	1524	680	3.05	494	2.21	4246	19.02
72	1829	566	2.54	343	1.54	3411	15.28
84	2134	485	2.17	252	1.13	2858	12.80
96	2438	425	1.90	193	0.86	2455	11.00
108	2743	377	1.69	152	0.68	2142	9.60
120	3048	340	1.52	123	0.55	1890	8.47

MOSC-210A CHANNEL							
BEAM SPAN OR COLUMN HT.		UNIFORM LOAD		UNIFORM LOAD AT DEFLECTION =1/240 SPAN		MAXIMUM COLUMN LOAD	
in	mm	lbs	kn	lbs	kn	lbs	kn
24	610	2480	11.11	2480	11.11	19047	85.33
36	914	2480	11.11	2480	11.11	18357	82.24
48	1219	2408	10.79	2408	10.79	17389	77.90
60	1524	1926	8.63	1926	8.63	16146	72.33
72	1829	1605	7.19	1605	7.19	14625	65.52
84	2134	1376	6.16	1278	5.72	12829	57.47
96	2438	1204	5.39	979	4.39	10755	48.18
108	2743	1070	4.79	773	3.46	8571	38.40
120	3048	963	4.31	626	2.80	6943	31.10

\* Limited by spot weld shear.

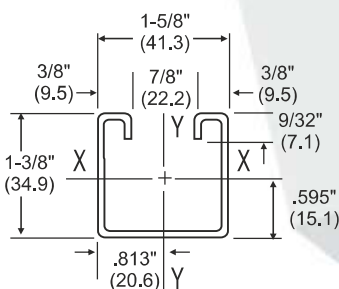

Wt. = 1.70 lbs/ft (2.53 kg/m)  
 Area = 0.502 in (3.24 cm)  
 I = 0.121 in (5.04 cm)  
 S = 0.155 in (2.54 cm)  
 R = 0.491 in (12.47 cm)  
 I = 0.206 in (8.57 cm)  
 S = 0.254 in (4.16 cm)  
 R = 0.640 in (16.26 cm)  
 Thickness = 12 GA (2.6 mm)

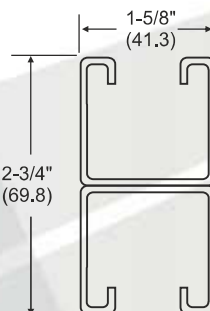

Wt. = 3.40 lbs/ft (5.06 kg/m)  
 Area = 1.004 in (6.48 cm)  
 I = 0.595 in (24.77 cm)  
 S = 0.433 in (7.10 cm)  
 R = 0.770 in (19.56 cm)  
 I = 0.412 in (17.15 cm)  
 S = 0.508 in (8.33 cm)  
 R = 0.640 in (16.26 cm)  
 Thickness = 12 GA (2.6 mm)

MOSC-300 CHANNEL							
BEAM SPAN OR COLUMN HT.		UNIFORM LOAD		UNIFORM LOAD AT DEFLECTION =1/240 SPAN		MAXIMUM COLUMN LOAD	
in	mm	lbs	kn	lbs	kn	lbs	kn
24	610	1291	5.78	1291	5.78	8193	36.70
36	914	861	3.86	861	3.86	6876	30.80
48	1219	645	2.89	504	2.26	5535	24.80
60	1524	516	2.31	322	1.44	4300	19.26
72	1829	430	1.93	224	1.00	3483	15.60
84	2134	369	1.65	164	0.73	2918	13.07
96	2438	332	1.49	126	0.56	2496	11.18
108	2743	287	1.29	99	0.44	2162	9.69
120	3048	258	1.16	80	0.36	1793	8.03

MOSC-300A CHANNEL							
BEAM SPAN OR COLUMN HT.		UNIFORM LOAD		UNIFORM LOAD AT DEFLECTION =1/240 SPAN		MAXIMUM COLUMN LOAD	
in	mm	lbs	kn	lbs	kn	lbs	kn
24	610	2150*	9.63	2150*	9.63	18275	81.87
36	914	2150*	9.63	2150*	9.63	17955	80.44
48	1219	1804	8.08	1804	8.08	16875	75.60
60	1524	1443	6.46	1443	6.46	15489	69.39
72	1829	1202	5.38	1101	4.93	13793	61.79
84	2134	1030	4.61	809	3.62	11790	52.82
96	2438	902	4.04	619	2.77	9472	42.43
108	2743	811	3.63	489	2.19	7484	33.53
120	3048	721	3.23	396	1.77	6062	27.16

\* Limited by spot weld shear.

# STRUT CHANNEL SYSTEMS

## Engineering Data

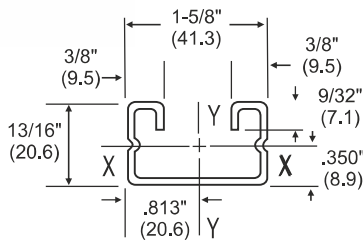

Wt. = 0.80 lbs/ft (1.19 kg/m)  
 Area = 0.226 in (1.46 cm)  
 I = 0.022 in (0.92 cm)  
 S = 0.048 in (0.79 cm)  
 R = 0.311 in (7.90 cm)  
 I = 0.085 in (3.54 cm)  
 S = 0.105 in (1.72 cm)  
 R = 0.613 in (15.57 cm)  
 Thickness = 16 GA (1.5 mm)

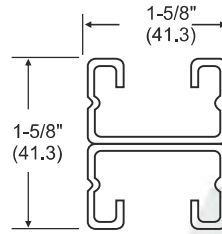

Wt. = 1.60 lbs/ft (2.38 kg/m)  
 Area = 0.452 in (2.91 cm)  
 I = 0.108 in (4.49 cm)  
 S = 0.133 in (2.18 cm)  
 R = 0.489 in (12.42 cm)  
 I = 0.170 in (7.08 cm)  
 S = 0.210 in (3.44 cm)  
 R = 0.613 in (15.57 cm)  
 Thickness = 16 GA (1.5 mm)

MOSC-400A CHANNEL							
BEAM SPAN OR COLUMN HT.		UNIFORM LOAD		UNIFORM LOAD AT DEFLECTION =1/240 SPAN		MAXIMUM COLUMN LOAD	
in	mm	lbs	kn	lbs	kn	lbs	kn
24	610	400	1.79	336	1.50	3930	17.61
36	914	266	1.19	162	0.73	3214	14.40
48	1219	200	0.90	91	0.41	2101	9.41
60	1524	160	0.72	58	0.26	1345	6.03
72	1829	133	0.60	40	0.18	934	4.18
84	2134	114	0.51	29	0.13	-	-
96	2438	100	0.45	22	0.10	-	-
108	2743	88	0.39	18	0.08	-	-
120	3048	80	0.36	14	0.06	-	-

MOSC-400A CHANNEL							
BEAM SPAN OR COLUMN HT.		UNIFORM LOAD		UNIFORM LOAD AT DEFLECTION =1/240 SPAN		MAXIMUM COLUMN LOAD	
in	mm	lbs	kn	lbs	kn	lbs	kn
24	610	630	2.82	630	2.82	8785	39.36
36	914	630	2.82	630	2.82	8072	36.16
48	1219	554	2.48	450	2.02	7074	34.69
60	1524	443	1.98	288	1.29	5790	25.94
72	1829	369	1.65	200	0.90	4257	19.07
84	2134	316	1.42	146	0.65	3128	14.01
96	2438	277	1.24	112	0.50	2394	10.73
108	2743	246	1.10	88	0.39	1892	8.48
120	3048	221	0.99	72	0.32	1532	6.86

\* Limited by spot weld shear.

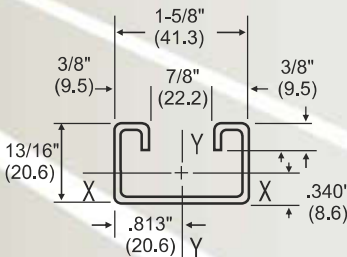

Wt. = 0.97 lbs/ft (1.44 kg/m)  
 Area = 0.290 in (1.87 cm)  
 I = 0.027 in (1.12 cm)  
 S = 0.057 in (0.93 cm)  
 R = 0.305 in (7.75 cm)  
 I = 0.108 in (4.49 cm)  
 S = 0.133 in (2.18 cm)  
 R = 0.610 in (15.49 cm)  
 Thickness = 14 GA (1.9 mm)

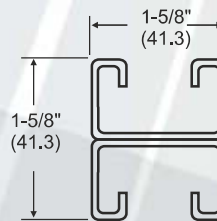

Wt. = 1.94 lbs/ft (2.89 kg/m)  
 Area = 0.580 in (3.74 cm)  
 I = 0.119 in (4.95 cm)  
 S = 0.146 in (2.39 cm)  
 R = 0.453 in (11.51 cm)  
 I = 0.216 in (8.99 cm)  
 S = 0.266 in (4.36 cm)  
 R = 0.610 in (15.49 cm)  
 Thickness = 14 GA (1.9 mm)

MOSC-500 CHANNEL							
BEAM SPAN OR COLUMN HT.		UNIFORM LOAD		UNIFORM LOAD AT DEFLECTION =1/240 SPAN		MAXIMUM COLUMN LOAD	
in	mm	lbs	kn	lbs	kn	lbs	kn
24	610	475	2.13	449	2.01	4917	22.03
36	914	316	1.42	199	0.89	3870	17.34
48	1219	237	1.06	112	0.50	2432	10.89
60	1524	190	0.85	71	0.32	1557	6.97
72	1829	158	0.71	49	0.22	1080	4.84
84	2134	135	0.60	36	0.16	-	-
96	2438	118	0.53	28	0.12	-	-
108	2743	377	0.47	22	0.10	-	-
120	3048	340	0.43	17	0.08	-	-

MOSC-500A CHANNEL							
BEAM SPAN OR COLUMN HT.		UNIFORM LOAD		UNIFORM LOAD AT DEFLECTION =1/240 SPAN		MAXIMUM COLUMN LOAD	
in	mm	lbs	kn	lbs	kn	lbs	kn
24	610	840	3.76	840	3.76	10921	48.93
36	914	811	3.63	811	3.63	9978	44.70
48	1219	608	2.72	608	2.22	8658	38.79
60	1524	486	2.18	317	1.42	6960	31.18
72	1829	406	1.81	220	0.99	5013	22.46
84	2134	345	1.55	161	0.72	3683	16.50
96	2438	304	1.36	123	0.55	2820	12.63
108	2743	270	1.21	97	0.43	2228	9.98
120	3048	243	1.09	79	0.35	-	-

# STRUT CHANNEL SYSTEMS

## Engineering Data

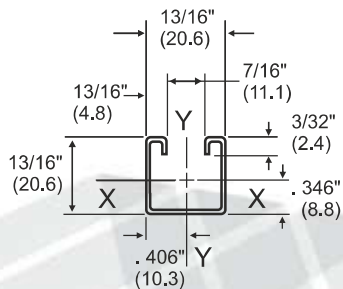

Wt. = 0.41 lbs/ft (0.61 kg/m)  
 Area = 0.122 in (0.79 cm)  
 I = 0.0102 in (0.42 cm)  
 S = 0.0219 in (0.14 cm)  
 R = 0.2891 in (7.34 cm)  
 I = 0.0134 in (0.56 cm)  
 S = 0.0329 in (0.54 cm)  
 R = 0.3314 in (8.42 cm)  
 Thickness = 19 GA (1.0 mm)

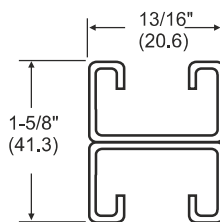

Wt. = 0.82 lbs/ft (1.22 kg/m)  
 Area = 0.244 in (1.57 cm)  
 I = 0.0498 in (2.07 cm)  
 S = 0.0614 in (1.01 cm)  
 R = 0.4518 in (11.48 cm)  
 I = 0.0268 in (1.11 cm)  
 S = 0.0658 in (1.08 cm)  
 R = 0.3314 in (8.42 cm)  
 Thickness = 19 GA (1.0 mm)

### MOSC-600 CHANNEL

BEAM SPAN OR COLUMN HT.		UNIFORM LOAD		UNIFORM LOAD AT DEFLECTION = 1/240 SPAN		MAXIMUM COLUMN LOAD	
in	mm	lbs	kn	lbs	kn	lbs	kn
12	305	291	1.30	291	1.30	1800	8.06
24	610	142	0.64	130	0.58	1353	6.06
36	914	99	0.44	60	0.27	877	3.93
48	1219	72	0.32	33	0.15	573	2.57
60	1524	59	0.26	22	0.10	414	1.85
72	1829	48	0.21	15	0.07	336	1.50

### MOSC-600A CHANNEL

BEAM SPAN OR COLUMN HT.		UNIFORM LOAD		UNIFORM LOAD AT DEFLECTION = 1/240 SPAN		MAXIMUM COLUMN LOAD	
in	mm	lbs	kn	lbs	kn	lbs	kn
12	305	345	1.54	345	1.54	3925	17.58
24	610	336	1.50	336	1.50	3710	16.62
36	914	272	1.22	270	1.21	3352	15.02
48	1219	207	0.93	165	0.74	2631	11.79
60	1524	161	0.78	103	0.46	1891	8.47
72	1829	138	0.62	74	0.33	1326	5.94

\* Limited by spot weld shear.

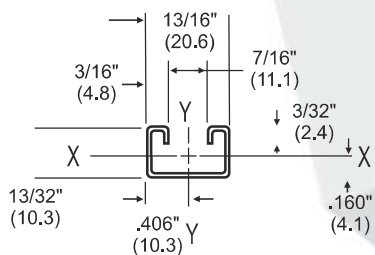

Wt. = 0.30 lbs/ft (0.45 kg/m)  
 Area = 0.085 in (0.55 cm)  
 I = 0.0017 in (0.07 cm)  
 S = 0.0070 in (0.11 cm)  
 R = 0.1414 in (3.59 cm)  
 I = 0.0077 in (0.32 cm)  
 S = 0.0190 in (0.31 cm)  
 R = 0.301 in (7.64 cm)  
 Thickness = 19 GA (1.0 mm)

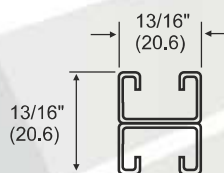

Wt. = 0.60 lbs/ft (0.89 kg/m)  
 Area = 0.170 in (1.10 cm)  
 I = 0.0078 in (0.32 cm)  
 S = 0.0191 in (0.31 cm)  
 R = 0.2142 in (5.44 cm)  
 I = 0.0154 in (0.64 cm)  
 S = 0.0380 in (0.62 cm)  
 R = 0.301 in (7.64 cm)  
 Thickness = 19 GA (1.0 mm)

### MOSC-700 CHANNEL

BEAM SPAN OR COLUMN HT.		UNIFORM LOAD		UNIFORM LOAD AT DEFLECTION = 1/240 SPAN		MAXIMUM COLUMN LOAD	
in	mm	lbs	kn	lbs	kn	lbs	kn
12	305	93	0.42	91	0.41	1426	6.39
24	610	46	0.21	22	0.10	875	3.92
36	914	31	0.14	10	0.04	394	1.76
48	1219	23	0.10	6	0.03	205	0.92
60	1524	18	0.08	4	0.02	131	0.59

### MOSC-700A CHANNEL

BEAM SPAN OR COLUMN HT.		UNIFORM LOAD		UNIFORM LOAD AT DEFLECTION = 1/240 SPAN		MAXIMUM COLUMN LOAD	
in	mm	lbs	kn	lbs	kn	lbs	kn
12	305	168	0.75	168	0.75	3083	13.81
24	610	127	0.57	101	0.45	2594	11.62
36	914	85	0.38	46	0.21	1779	7.97
48	1219	64	0.29	26	0.12	931	4.17
60	1524	51	0.23	16	0.07	596	2.67

# STRUT CHANNEL SYSTEMS

## Engineering Data

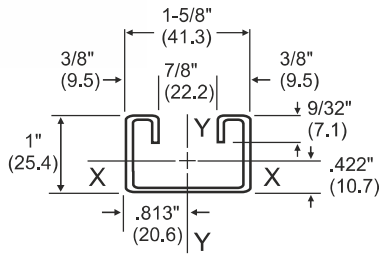

Wt. = 1.44 lbs/ft (2.14 kg/m)  
 Area = 0.426 in (2.75 cm)  
 I = 0.053 in (2.21 cm)  
 S = 0.092 in (1.51 cm)  
 R = 0.352 in (8.94 cm)  
 I = 0.160 in (1.06 cm)  
 S = 0.197 in (3.23 cm)  
 R = 0.613 in (15.57 cm)  
 Thickness = 12 GA (2.6 mm)

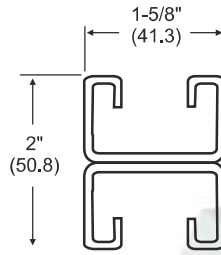

Wt. = 2.88 lbs/ft (4.28 kg/m)  
 Area = 0.852 in (5.49 cm)  
 I = 0.255 in (10.61 cm)  
 S = 0.255 in (4.18 cm)  
 R = 0.547 in (13.89 cm)  
 I = 0.320 in (13.32 cm)  
 S = 0.394 in (6.46 cm)  
 R = 0.613 in (15.57 cm)  
 Thickness = 12 GA (2.6 mm)

MOSC-800 CHANNEL							
BEAM SPAN OR COLUMN HT.		UNIFORM LOAD		UNIFORM LOAD AT DEFLECTION = 1/240 SPAN		MAXIMUM COLUMN LOAD	
in	mm	lbs	kn	lbs	kn	lbs	kn
24	610	766	3.43	766	3.43	7275	32.58
36	914	511	2.29	392	1.76	6345	28.43
48	1219	383	1.72	220	0.99	4684	20.98
60	1524	306	1.37	141	0.63	3160	14.16
72	1829	255	1.14	98	0.44	2195	9.83
84	2134	219	0.98	72	0.32	1612	7.22
96	2438	191	0.86	55	0.25	-	-
108	2743	170	0.76	43	0.19	-	-
120	3048	153	0.68	35	0.16	-	-

MOSC-800A CHANNEL							
BEAM SPAN OR COLUMN HT.		UNIFORM LOAD		UNIFORM LOAD AT DEFLECTION = 1/240 SPAN		MAXIMUM COLUMN LOAD	
in	mm	lbs	kn	lbs	kn	lbs	kn
24	610	1550	6.94	1550	6.94	17781	79.66
36	914	1416	6.34	1416	6.34	16284	72.95
48	1219	1062	4.76	1056	4.73	14525	65.07
60	1524	850	3.81	680	3.05	12515	56.07
72	1829	708	3.17	472	2.11	10248	45.91
84	2134	607	2.72	346	1.55	7780	34.85
96	2438	531	2.38	265	1.19	5957	26.69
108	2743	472	2.11	209	0.94	4707	21.09
120	3048	425	1.90	170	0.76	3812	17.08

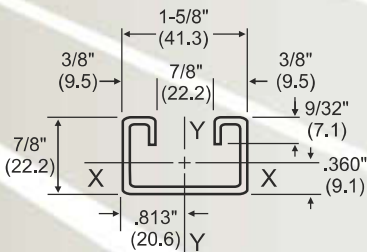

Wt. = 1.36 lbs/ft (2.02 kg/m)  
 Area = 0.400 in (2.58 cm)  
 I = 0.040 in (1.66 cm)  
 S = 0.078 in (1.28 cm)  
 R = 0.316 in (8.03 cm)  
 I = 0.148 in (6.16 cm)  
 S = 0.182 in (2.98 cm)  
 R = 0.608 in (15.44 cm)  
 Thickness = 12 GA (2.6 mm)

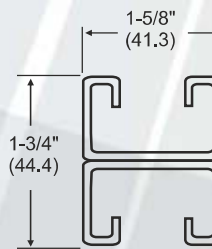

Wt. = 2.72 lbs/ft (4.05 kg/m)  
 Area = 0.800 in (5.16 cm)  
 I = 0.180 in (7.49 cm)  
 S = 0.206 in (3.38 cm)  
 R = 0.474 in (12.04 cm)  
 I = 0.296 in (12.32 cm)  
 S = 0.364 in (5.97 cm)  
 R = 0.608 in (15.44 cm)  
 Thickness = 12 GA (2.6 mm)

MOSC-900 CHANNEL							
BEAM SPAN OR COLUMN HT.		UNIFORM LOAD		UNIFORM LOAD AT DEFLECTION = 1/240 SPAN		MAXIMUM COLUMN LOAD	
in	mm	lbs	kn	lbs	kn	lbs	kn
24	610	650	2.91	642	2.88	7858	35.20
36	914	433	1.94	296	1.33	6198	27.77
48	1219	325	1.46	166	0.74	4101	18.37
60	1524	260	1.16	106	0.47	2648	11.86
72	1829	216	0.97	74	0.33	1838	8.26
84	2134	185	0.83	54	0.24	-	-
96	2438	162	0.73	41	0.18	-	-
108	2743	144	0.64	32	0.14	-	-
120	3048	130	0.58	26	0.12	-	-

MOSC-900A CHANNEL							
BEAM SPAN OR COLUMN HT.		UNIFORM LOAD		UNIFORM LOAD AT DEFLECTION = 1/240 SPAN		MAXIMUM COLUMN LOAD	
in	mm	lbs	kn	lbs	kn	lbs	kn
24	610	1350	6.05	1350	6.05	17490	78.35
36	914	1144	5.12	1144	5.12	15695	70.31
48	1219	858	3.84	750	3.36	13558	60.74
60	1524	686	3.07	480	2.15	11097	49.71
72	1829	572	2.56	333	1.49	8290	37.14
84	2134	490	2.19	244	1.09	6096	27.31
96	2438	429	1.92	187	0.84	4668	20.91
108	2743	381	1.71	148	0.66	-	-
120	3048	343	1.54	120	0.54	-	-



Coverage Unlimited



**Corporate Office MIDDLE EAST**  
**Jv-One MIDDLE EAST FZE**  
P.O Box: 16653 Rakftz, Ras Al Khaimah UAE  
Email: [venture@jv-one.com](mailto:venture@jv-one.com)

**Manufacturing Plant**  
**Jv-One Saudi Company**  
Second Industrial City, Dammam, Saudi Arabia  
P.O Box: 3081, Al Dammam-31471 KSA  
Email: [sales@jv-one.com](mailto:sales@jv-one.com)

